



## **The Top Choice (Battery Backup System)**

- **INSTALLATION  
& START-UP MANUAL**
- **OPERATION MANUAL**

Documentation # 6002-1621

Revision A

| TABLE OF CONTENTS |   | PAGE  |
|-------------------|---|-------|
| 1.                | REVISION HISTORY                            | 2     |
| 2.                | COMPANY INTRODUCTION AND SAFETY INFORMATION | 3~6   |
| 3.                | INSTALLATION AND START-UP MANUAL            | 7~19  |
| 4.                | OPERATION'S MANUAL                          | 20~58 |

**REVISION HISTORY**

| <u>REV</u> | <u>DATE</u>        | <u>PRIMARY REASON FOR CHANGE</u> |
|------------|--------------------|----------------------------------|
| X1.....    | APRIL 4, 2004..... | RELEASE FOR PRODUCTION           |
| X2.....    | FEBRUARY 22, 2005  | RELEASE FOR PRODUCTION           |
| A.....     | APRIL 11, 2005     | RELEASE FOR PRODUCTION           |
| B.....     | MAY 20, 2005       | RELEASE FOR PRODUCTION           |
| C.....     | JUL 20, 2005       | RELEASE FOR PRODUCTION           |

**LIST OF EFFECTIVE PAGES**

| <u>PAGE</u> | <u>REV</u> | <u>PAGE</u> | <u>REV</u> | <u>PAGE</u> | <u>REV</u> |
|-------------|------------|-------------|------------|-------------|------------|
| 1~19        | C          |             |            |             |            |
| 20~58       | C          |             |            |             |            |

Congratulations on selecting one of the fine products from Crucial Power, the Leader in Power Protection Technology. Our wide product offering includes Uninterruptible Power Systems (UPS), Power Conditioners, Automatic Voltage Regulators and Specialty Transformers (e.g. computer-grade, medical-grade). Since our beginning, Crucial Power has shipped many of these fine products around the world, to discerning customers, for use on sensitive equipment and critical applications. Our customers, both new and long-time, continue to enjoy security and peace of mind as they realize what it means to "When the lights go out, we turn on".

## **HEADQUARTERS**

Crucial Power  
5701 Smith Street  
Commerce, CA 90040

## **SALES**

Phone (800) 227-8899  
Phone (323) 278-9550  
FAX No. (323) 278-9555  
email: [sales@crucialpower.com](mailto:sales@crucialpower.com)

Office Hours  
7:30 AM to 5:00 PM PST

## **NOTICE: THIS DOCUMENT CONTAINS PROPRIETARY INFORMATION**

This document contains proprietary and confidential information of Crucial Power, Inc. ("Crucial Power"). In consideration of the receipt of this document, the recipient agrees not to copy any of its contents, nor disclose them to or allow them to be used by any person not currently a Crucial Power employee or an employee of the recipient having a need to know, without the express written consent of Crucial Power, and further agrees to surrender this document to Crucial Power when the reason for its receipt has terminated.

## SAFETY

Safety precautions are important when operating or servicing electrical equipment. The following symbols are used extensively throughout this manual. Always use these precautions since they are essential to the safe operation and servicing of this product.



**THIS DANGER SYMBOL IDENTIFIES A CONDITION OR ACTION WHICH WILL RESULT IN SEVERE INJURY OR DEATH TO AN INDIVIDUAL OR SEVERE DAMAGE TO EQUIPMENT OR OTHER PROPERTY.**



**This Caution symbol identifies a condition or action which may result in minor injury to an individual or minor damage to the equipment or other property.**

This unit was designed for specific applications. It should **not** be modified and/or used for any application other than for that which it was designed. Optional equipment not described in the sales literature or this manual should not be installed without first checking with the Service department. If you have any questions about this unit's application call the Service department at the number shown on the previous page.

## **IMPORTANT SAFETY INSTRUCTIONS SAVE THESE INSTRUCTIONS**

This technical manual contains important instructions that should be followed during installation and maintenance of the TOP CHOICE System.

## BATTERY / STORAGE

- A Battery's life of TOP CHOICE – the battery's life of TOP CHOICE is about 3-6 years under normal usage.
- B. Caution: Do not dispose of battery in fire  
Caution: Do not attempt to open the battery  
Caution: The following precautions should be taken when replacing the battery  
Remove watches, rings, etc.
- C. Use tools with insulated handles.
- D Battery is supplied as separate individual quantity. Connection should be in series and DC volt is 48 VDC (4x12 volt).
- E Storage condition – Store the UPS control unit – cover and upright in a cool, dry, location, with its battery fully charged. Before storing, charge the UPS for at least four hours. Remove any accessories in the accessory slot and disconnect any cables connected to the computer interface port to avoid unnecessary draining the battery.
- F Extended storage – During extended storage in environments where the ambient temperature is  $-15^{\circ}\text{C}$  to  $+30^{\circ}\text{C}$  ( $+5$  degree F to  $+86$  degree F), charge the UPS' s battery every six months.

Extended storage – During extended storage in environments where the ambient temperature is  $-30$  degree to  $+45$  degree C ( $+86$  degree F to  $+113$  degree F), charge the UPS' s battery every 3 months.

## UNPACKING AND INSPECTION

1. Carefully open the shipping package and remove the unit and other contents and make sure the following items are included.
  - One UPS controller unit with temperature sensor.
  - One installation and start-up manual and operator's
  - Qty. four 12V, 65AH batteries.
  - One interconnection harness.
  - Battery connection plug and jumpers.

**Read the manual before installation. Follow the installation instruction and connection diagram in the manual.**



**Blank intentionally**

**CRUCIAL POWER**

**INSTALLATION AND START-UP MANUAL**

## TABLE OF CONTENTS

|  |      |
|--|------|
| 1. INSTALLATION AND START-UP MANUAL  | PAGE |
| 1.1 BATTERY BACK-UP SYSTEM – DESCRIPTION (TOP CHOICE).....                               | 10   |
| 1.1.1 SYSTEM FUNCTIONAL DESCRIPTION.....   | 11   |
| 1.1.2 UPS CONTROL UNIT (A).....  | 12   |
| 1.1.3 MBS / PTS [ MANUAL BYPASS SWITCH ] (B) .....<br>AND POWER TRANSFORMER SWITCH ..... | 12   |
| 1.1.4 BATTERIES (C).....   | 14   |
| 1.2 INSTALLATION.....  | 14   |
| 1.2.1 INSPECTION.....  | 15   |
| 1.2.2 INSTALL UPS.....   | 15   |
| 1.2.3 CONNECT BATTERY PACK.....  | 15   |
| 1.2.4 LOAD AND INPUT WIRING.....   | 16   |
| 1.2.5 INTERCONNECTION WIRING BETWEEN UPS CONTROL UNIT.....<br>AND MBS / PTS ASSY.        | 16   |
| 1.2.6 INTERCONNECTION BETWEEN BATTERY AND UPS CONTROL UNIT.....                          | 17   |
| 1.2.7 COMPLETE INSTALLED SYSTEM DIAGRAM.....   | 17   |
| 1.3 START-UP / SHUT DOWN STEPS.....  | 18   |
| 1.3.1 START-UP THE UNIT .....  | 18   |
| 1.3.2 SHUT-DOWN STEP.....  | 18   |
| 1.3.3 UPS CONTROL UNIT SHUT-DOWN.....  | 18   |
| 1.3.4 MBS / PTS SHUT DOWN.....   | 19   |
| 1.4 TROUBLE SHOOTING.....  | 20   |
| 1.5 EMERGENCY SHUTDOWN STEP.....   | 21   |

## 1.1 BATTERY BACK-UP SYSTEM DESCRIPTION

### 1.1.1 SYSTEM FUNCTIONAL DESCRIPTION

The On-Line battery back-up system provides the Uninterruptible power to traffic control and signal equipment. The total maximum power is 750 watt at 74°C environmental condition.

The TOP CHOICE has a unique system protection scheme to supply the uninterrupted power to the critical traffic control and signal system whether the in-coming power line voltage is out of specified range or without unit and batteries.

This function is accomplished by providing a power transfer switch (PTS) and manual maintenance bypass switch. Batteries provide back-up power when the input line voltage is out of voltage range or completely failed.

These four components can be mounted in an enclosure as required. The figure 1 is a simplified system block diagram.

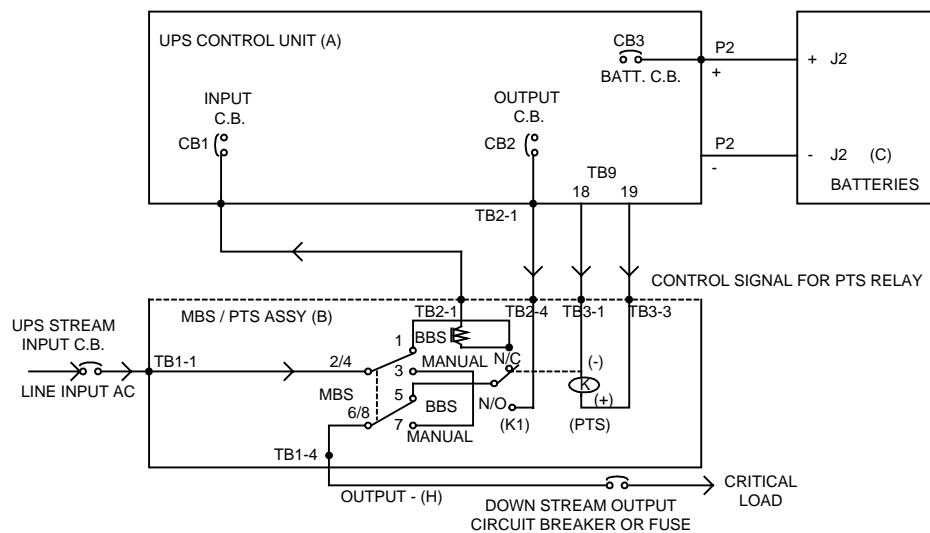

FIGURE 1: A SIMPLIFIED BBS BLOCK DIAGRAM

The line power is applied to the MBS / PTS Assy. & the line power thru PTS support the critical load when the input line voltage is within the specified range. It is called off-line UPS when the line voltage is out of specified range or failed. Then the UPS controller detects this condition and send a signal to PTS relay and the PTS relay is energized and the output of UPS controller is now support the critical load until the line power is recovered or the batteries are fully discharged. The operating time of this mode depends upon the battery's status and the size of load. The online TOP CHOICE is designed for maximum two hours from battery source at 750 watt load.

## 1.1.2 UPS CONTROLLED UNIT (A)

The UPS controller unit provides control functions and is monitoring the input line voltage continuously to detect the input line condition.

For detail, refer to the section 2, operation.  
Figure 2 is shown the front panel.

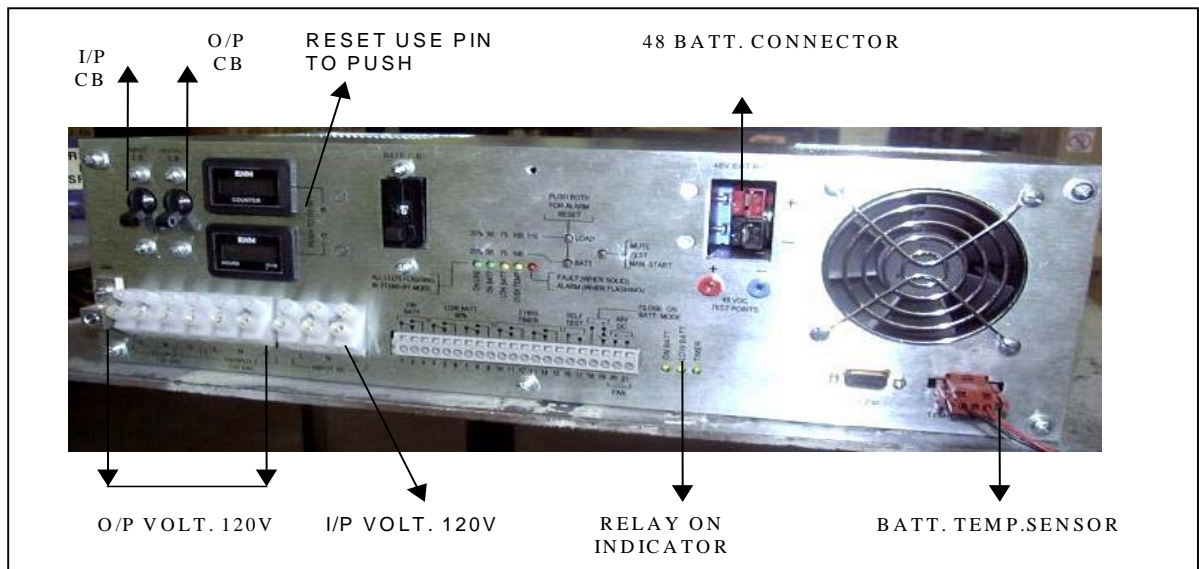

## 1.1.3 MBS / PTS (MANUAL BYPASS SWITCH AND POWER TRANSFER SWITCH (B))

The power transfer switch (PTS) provides “off-line UPS” function and allows also the UPS control unit to be removed for replacement without interruption of power to critical load. And provides a power flow path to critical load from the UPS control unit when the input line voltage is out of specified range or input fails.

The manufacturing switch (MBS) provides a means of transferring the input line power to critical load directly and allows completely the battery back-up system to be removed.

Figure 3 is MBS / PTS Assy.

FIGURE 3: MBS / PTS ASSY.

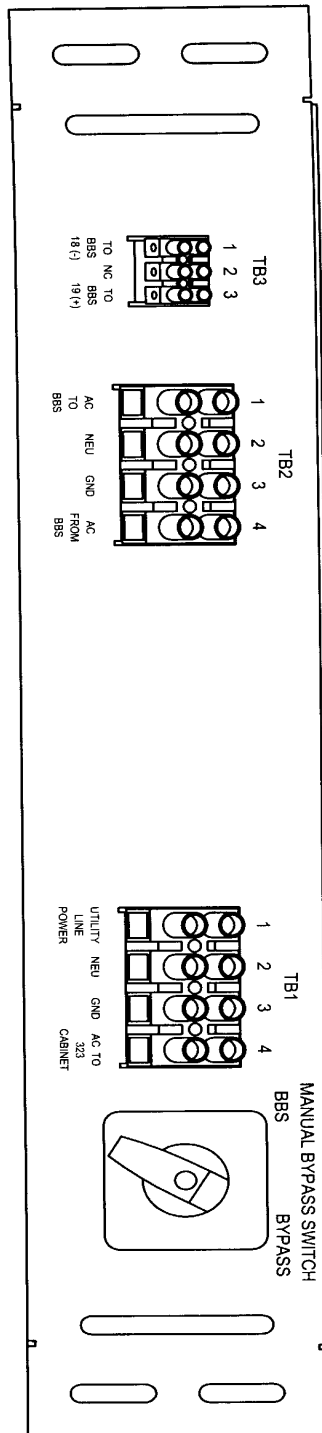

## 1.1.4 BATTERIES (C )

The battery voltage is 48 VDC, 12V / cell, qty. 4, and provides 2 hours back-up time at 750 watt load. Battery is supplied as separate individual quantity, connection should be in series.

Battery connection diagram is enclosed in each TOP CHOICE shipping packages.

### BATTERY SAFETY

1. Servicing of batteries should be performed or supervised by personnel knowledgeable of batteries and the required precautions.
  - Keep unauthorized personnel away from the batteries.
2. When replacing batteries, replace with the same number and same manufactures. Type and Model that was supplied with unit.
3. Caution – Do not dispose of battery or batteries in a fire.
  - The battery may EXPLODE.
4. Caution – Do not open or mutilate the batteries.
  - Released electrolyte is harmful to the skin and eyes.
  - The electrolyte can be toxic.
5. Caution – A battery can present a risk of electrical shock and has high short circuit current, that can cause arc flash dangerous to your eyes.

The following precautions should be observed when working on batteries.

- Remove watches, rings, or other metal objects
- Use tools with insulated handles.
- Wear rubber gloves and boots.
- Do not lay tools or metal parts on top of batteries.
- Disconnect charging source prior to connecting or disconnecting battery terminal
- Determine if battery is inadvertently grounded.

If battery is inadvertently grounded, remove the ground.

Contact with any part of a grounded battery can result in electrical shock

The likelihood of such shock will be reduced if such grounds are removed during installation, and maintenance.

All battery terminal connections shall be TORQUED to 75 in / lbs.

## 1.2 INSTALLATION

- 1.2.1 Inspection the ups upon receipt.
- 1.2.2 Install the UPS in a protected area with adequate airflow and free of excessive dust. Do not operate the UPS where the temperature and humidity is outside the specified limits.
- 1.2.3 Connect Battery Pack – refer to battery installation. Before connecting, make sure the battery pack and connector cable are compatible

Note: External battery connection is necessary. The UPS does not work properly without external battery pack connection.

Caution: Use only factory supplied or external battery connection cable.

### INSTALL UP TO 4 BATTERY-PACKS PER UPS

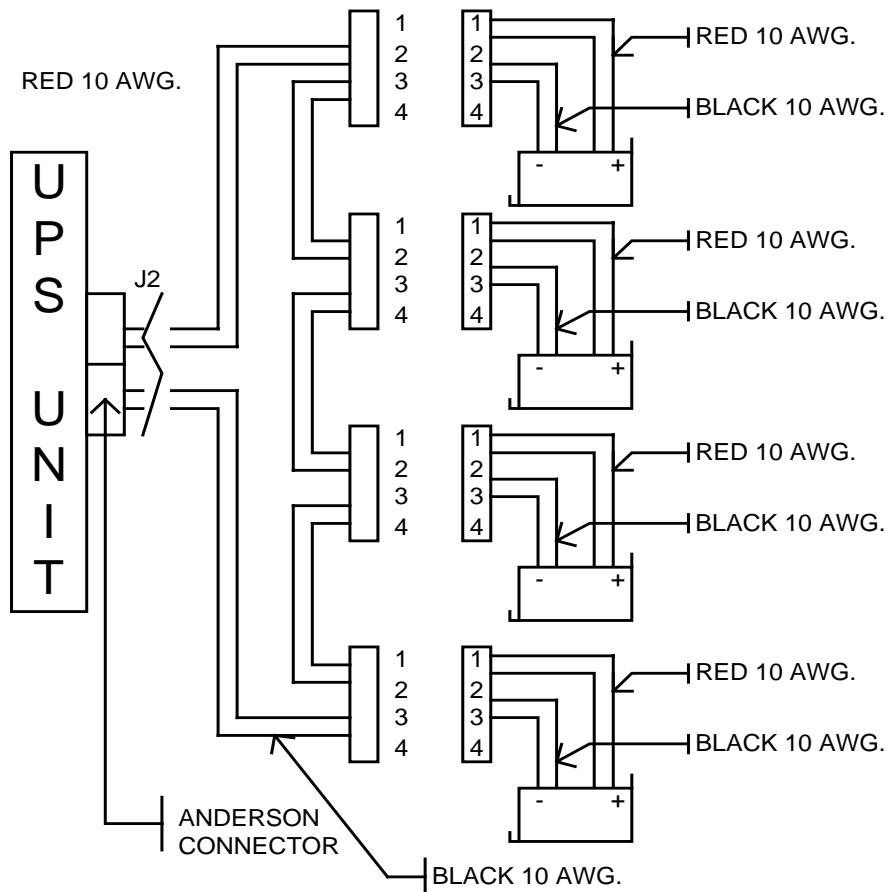

**DANGER WARNING:**

The input line power must have a circuit breaker or fuse protection as per the local electrical code. Refer to figure 1 – upstream input circuit breaker in this manual. Prior to wire the input power cable, make sure that there is no live voltage at load side upstream circuit breaker or fuse. If no live voltage, then only, proceed the next step. Before wiring, make sure, all circuit breakers in UPS control unit are “OFF POSITION”.

## 1.2.4 LOAD / INPUT WIRING

Connect as follow using harness 7060-1091-01 assembly

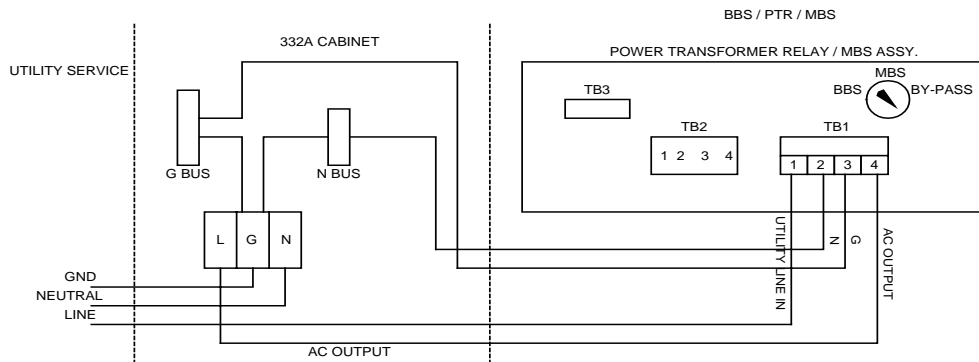

## 1.2.5 INTERCONNECTION WIRING BETWEEN UPS CONTROL UNIT AND MBS / PTS ASSY. USE HARNESS # 7060-1096-01.

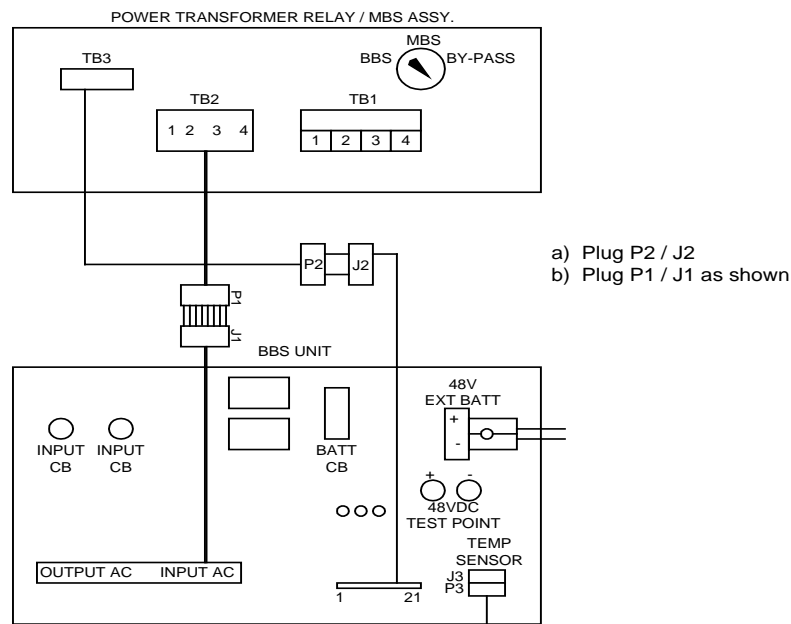

## 1.2.6 INTERCONNECTION BETWEEN BATTERY AND UPS CONTROL UNIT. PLUG P2 (48V EXT BATT) OF BATTERY TO J2 OF UPS (48V EXT BATT) CONTROL UNIT

USING HARNESS 7060-1089-01

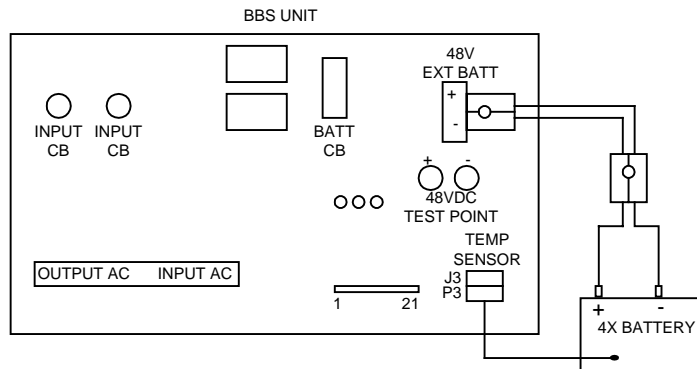

**WARNING:** @ TEMP. SENSOR MUST BE CONNECTED ALWAYS FIRST WITH BATTERIES. WITHOUT SENSOR, BATTERIES MAY BE DAMAGED BY OVER CHARGING.

### 1.2.7 COMPLETE INSTALLED UNITS.

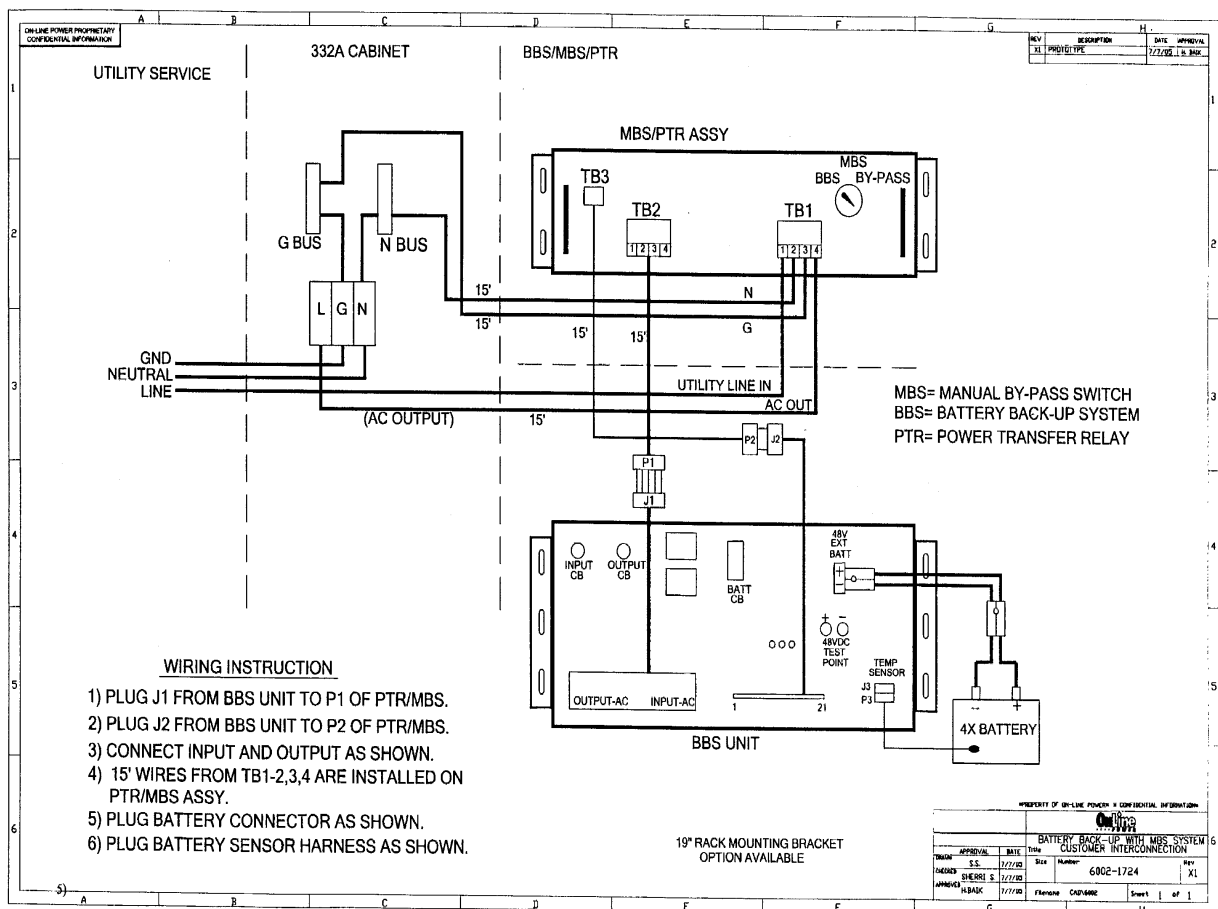

### 1.3 START-UP & TURN ON STEPS / SHUT DOWN STEPS

### 1.3.1 START-UP UNIT – MAKE SURE THE MBS ON “AUTO POSITION” IN MBS / PTS ASSY.

- STEP 1 – CLOSE INPUT CIRCUIT BREAKER (CB1)
  - STEP 2 – CLOSE OUTPUT CIRCUIT BREAKER (CB2)
  - STEP 3 – CLOSE BATTERY CIRCUIT BREAKER (CB3)
- UNIT WILL TURN ON IN ABOUT 30 SECONDS.

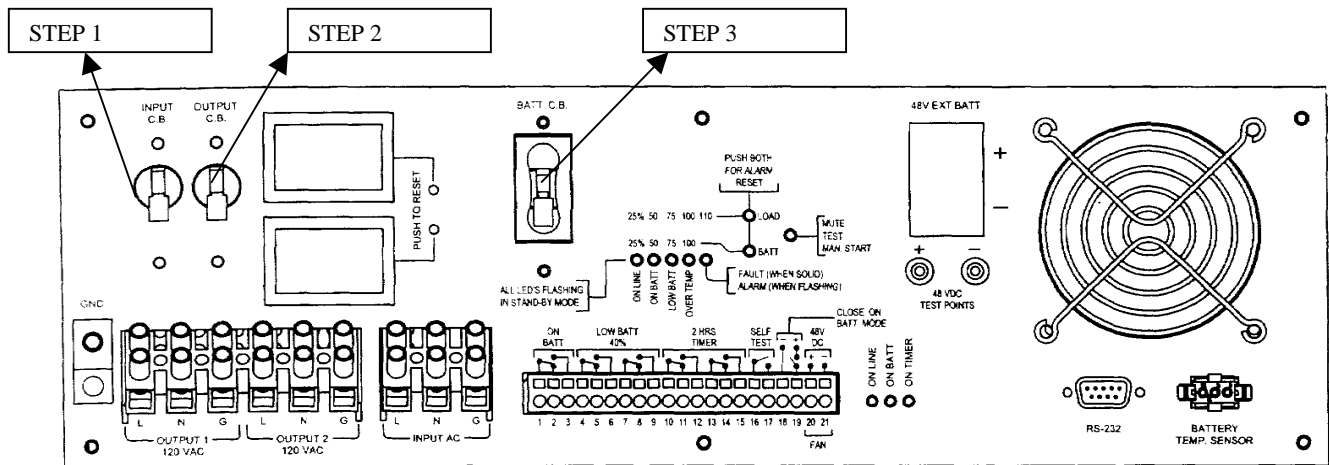

### 1.3.2 SHUT DOWN STEPS



#### “DANGER WARNING”

Even when the unit is off, there is potentially dangerous voltages within the unit due to the batteries and line power connection. Extreme care must be taken when working within the TOP CHOICE system

#### 1.3.2.1 UPS control unit shut down

- Step 1 – Turn off the battery circuit breaker.
- Step 2 – Turn off the input circuit breaker.
- Step 3 – Turn off the output circuit breaker.
- Step 4 – Unplug the J2-connector from the unit.
- Step 5 – Disconnect PTS control signals from TB-18 and TB-19.
- Step 6 – Disconnect the input and output wires from TB1 & TB2 of unit.  
And isolate the wires individually using electrical tape.
- Step 7 – Remove or perform maintenance on the UPS control unit.

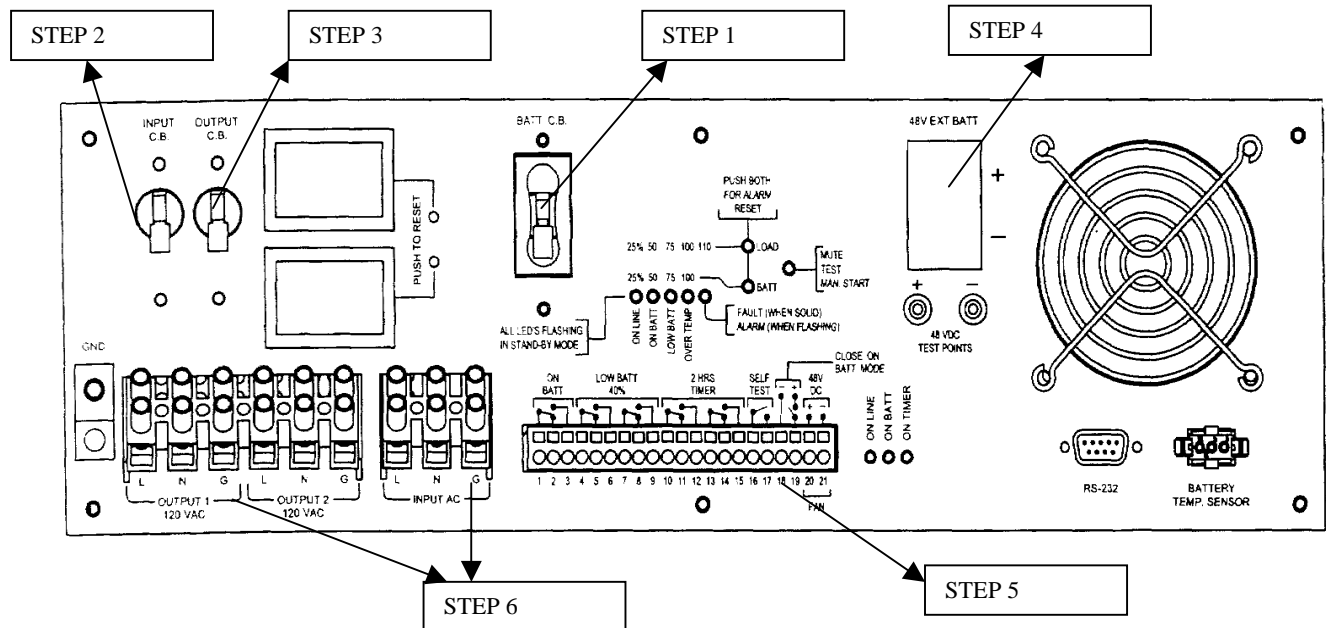

**“WARNING”**

Since this TOP CHOICE unit is off line unit and has manual bypass switch and power transfer switch functions, the critical load is still supporting through power transfer switch due to UPS control unit disconnection.

If desire, switch MBS to manual position for making sure there will be no power interruption during the shut down unless the main input power to TOP CHOICE is disconnected.

**1.3.2.2 MBS / PTS SHUT DOWN**

Turn off the UPS stream input circuit breaker. This removes the power from TOP CHOICE system completely at this point.

Now is safe to disconnect the wires from TB1 & TB2 and TB3.

Remove or perform maintenance on the MBS / PTS assembly.

The end of shut down.

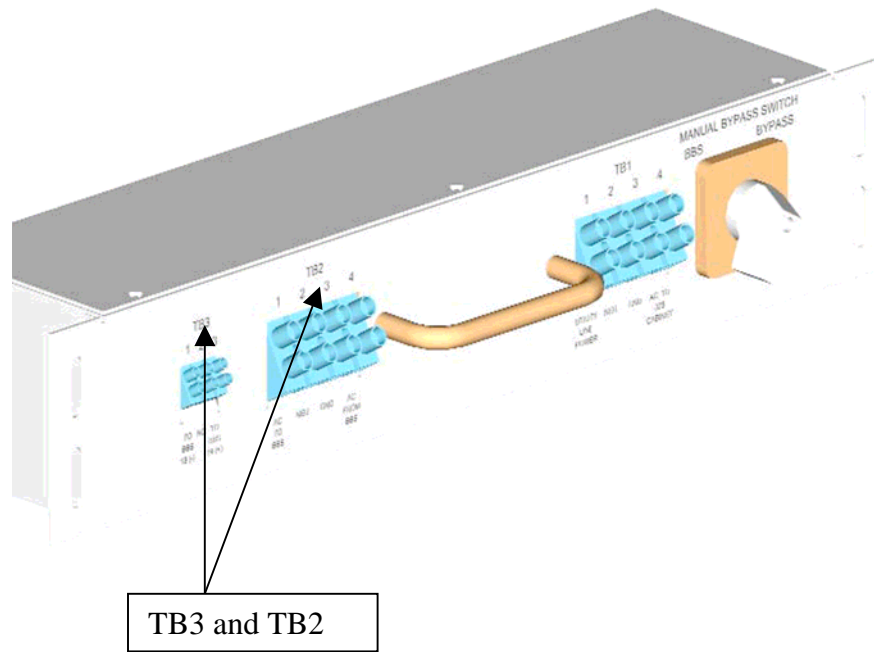

## 1.4 TROUBLE SHOOTING

- The TOP CHOICE (Battery Backup System) is designed to only need minimum maintenance through its life.
- The only required periodic maintenance is to clean the unit and vacuum the ventilation intake.
- The battery connections should be checked periodically for the proper torque to insure that the connections are good.
- The unit's electronics require no maintenance.

If the unit fails to perform a specific function, a listing on the next page shows typical problem symptoms, their causes and their solutions, starting with the most obvious and working systematically. If you cannot fix a particular problem, contact Crucial Power's Customer Service Department. By following this manual's guidelines, you will have many years of trouble free service.

| <u>SYMPTOM</u>   | <u>CAUSE</u>                                 | <u>REMEDY</u>   |
|--|--|---|
| TOP CHOICE DOES NOT TURN ON WHEN BATTERY CIRCUIT BREAKER IS TURNED ON.           | POWER ON CIRCUIT IS DISABLED                 | CONNECT LINE POWER AND RE-START<br>WAIT 5 MINUTES FOR THE POWER CIRCUIT TO RESET. |
|  | DEAD BATTERY                                 | CONNECT A KNOWN GOOD BATTERY  |
|  | BATTERY CIRCUIT BREAKER OFF.                 | TURN THE BATTERY CIRCUIT BREAKER ON   |
|  | FAULTY UNIT                                  | CONTACT VENDOR  |
| ONLINE MODE DOES NOT COME ON   | NO LINE POWER                                | WAIT FOR LINE POWER<br>SEE THE UPSTREAM CIRCUIT BREAKER IS ON                     |
|  | LINE VOLTAGE TOO LOW                         | WAIT FOR VOLTAGE TO COME UP TO ACCEPTABLE LEVEL                                   |
|  | AC INPUT & OUTPUT CIRCUIT BREAKER TURNED OFF | TURN IT ON  |
| ON BATTERY MODE DOES NOT COME ON DURING A POWER FAILURE OR DURING A MANUAL START | LOW BATTERY CHARGE                           | CHARGE THE BATTERIES  |
|  | FAULTY UNIT                                  | CONTACT VENDOR  |
| BACK-UP TIME IS LESS THAN RATED OR THERE IS A FLASHING LOW BATTERY LED           | BATTERY IS NOT FULLY CHARGED                 | FULLY RECHARGE THE BATTERY, THEN TEST BACKUP TIME                                 |
|  | DEAD BATTERY                                 | CONNECT A GOOD BATTERY  |
|  | BATTERY CIRCUIT BREAKER OFF                  | TURN THE BATTERY CIRCUIT BREAKER ON   |
|  | BATTERY FAILURE                              | CLEAN AND TIGHTEN BATTERY CONNECTIONS   |
|  |  | CHECK BATTERY AND REPLACE IT NEEDED   |
| FAULTY UNIT  | CONTACT VENDOR                               |   |
| FAULT LED IS ON OR FLASHING  | CHECK FAULT CODES                            | CORRECT FAULT   |
|  |  | CONTACT VENDOR  |

## 1.5 EMERGENCY SHUTDOWN STEP

- STEP 1 – TURN OFF THE BATTERY CIRCUIT BREAKER
- STEP 2 – TURN OFF THE UPS STREAM CIRCUIT BREAKER
- STEP 3 – TURN OFF THE INPUT CIRCUIT BREAKER (CB1)
- STEP 4 – UNPLUG THE J2 CONNECTOR FROM BATTERIES.

## "EMERGENCY SHUT DOWN FINISH"

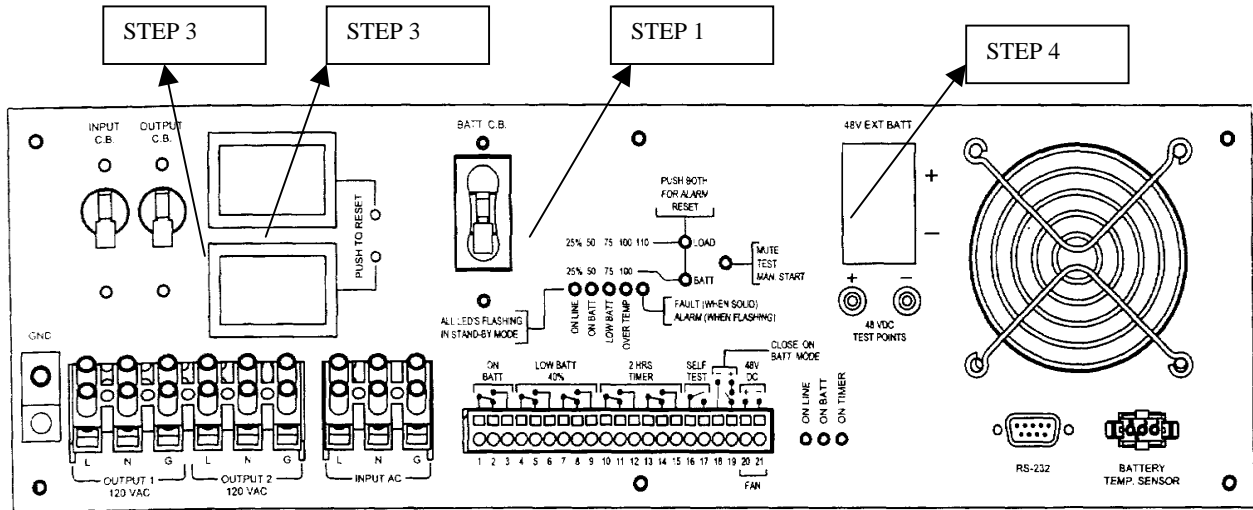

**Blank intentionally**

**OPERATOR'S MANUAL**

**BATTERY BACK-UP SYSTEM**

## About Our Products and Crucial Power

Congratulations on selecting one of the fine products from Crucial Power, the Leader in Power Protection Technology. Our wide product offering includes Uninterruptible Power Systems (UPS), Power Conditioners, Automatic Voltage Regulators and Specialty Transformers (e.g. computer-grade, medical-grade). Since our beginnings in 1975, Crucial Power has shipped thousands of these fine products around the world to discerning customers for use on sensitive equipment and critical applications. Our customers, both new and long-time, continue to enjoy security and peace of mind as they realize what it means to "Stay On Line with Crucial Power". One of our goals is to make these manuals both comprehensive and easy to use. This new-format technical manual is the result of ideas and inputs from customers who have taken an active interest in our continued success. We invite constructive feedback on our products and documentation via fax, mail, telephone or email.

### HEADQUARTERS

Crucial Power, Inc  
5701 Smithway Street  
Commerce, CA 90040

Crucial Power, Inc.  
5940 Triumph Street  
Commerce, CA 90040

### SALES:

Phone (800) 227-8899  
Inside CA (323) 278-9550  
FAX No. (323) 278-9555

### MANUFACTURING:

Phone (323) 720-4125  
Fax (323) 889-6636

*<http://www.crucialpower.com>  
email: [info@crucialpower.com](mailto:info@crucialpower.com)*

### SERVICE

Phone (800) 797-7782  
(PWR-SRVC)  
FAX No. (323) 278-9555

**Crucial Power, Inc. Proprietary**

**Reproduction Unauthorized**

**Distribution is Forbidden**

**NOTICE: THIS DOCUMENT CONTAINS PROPRIETARY  
INFORMATION**

This document contains proprietary and confidential information of Crucial Power, Inc. ("Crucial Power"). In consideration of the receipt of this document, the recipient agrees not to copy any of its contents, nor disclose to or allow the information contained herein to be used by any person who is not currently an Crucial Power employee or an employee of the recipient having a need to know without the express written consent of Crucial Power, and furthermore agrees to surrender this document to Crucial Power when the reason for its receipt no longer exists.

| <b>TABLE OF CONTENTS:</b> |  | <b>PAGE</b> |
|---------------------------|--|-------------|
| <b>1.0</b>                | <b>GENERAL DESCRIPTION.....</b>  | <b>29</b>   |
| 1.1.1                     | SYSTEM STRUCTURE.....  | 29          |
| 1.1.2                     | BASIC SYSTEM DESCRIPTION.....  | 29          |
| 1.1.3                     | COOLING.....   | 29          |
| 1.1.4                     | BATTERY POLARITY.....  | 29          |
| <b>2.0</b>                | <b>SPECIFICATION / GENERAL CHARACTERISTICS INPUT/OUTPUT... 30</b>        |             |
| 2.1.1                     | INPUT SPECIFICATION.....   | 30          |
| 2.1.2                     | OUTPUT SPECIFICATION.....  | 30          |
| 2.1.3                     | BATTERY BACK-UP TIME.....  | 30          |
| 2.1.4                     | TRANSFER TIME.....   | 30          |
| 2.1.5                     | N/O & N/C CONTACTS (3 SETS).....   | 30          |
| 2.1.6                     | OPERATING TEMPERATURE.....   | 30          |
| 2.1.7                     | TRANSFER RELAY AND MANUAL BY-PASS SWITCH.....                            | 30          |
| 2.1.8                     | TEMPERATURE COMPENSATED BATTERY / CHARGER.....                           | 30          |
| 2.1.9                     | TEMPERATURE SENSOR.....  | 31          |
| 2.1.10                    | BATTERY TEMPERATURE 50°C .....   | 31          |
| 2.1.11                    | INPUT VOLTAGE 100-130V RANGE.....  | 31          |
| 2.1.12                    | OUTPUT VOLTAGE WITH BATTERY POWER.....                                   | 31          |
| 2.1.13                    | CABINET COMPATIBILITY.....   | 31          |
| 2.1.14                    | RESTORING UTILITY AT 105VAC ±2V.....                                     | 31          |
| 2.1.15                    | RESTORING UTILITY AT 125VAC ±2V.....                                     | 31          |
| 2.1.16                    | NO FEEDBACK TO UTILITY SOURCE.....                                       | 31          |
| 2.1.17                    | POWER TRANSFER RELAY.....  | 31          |
| 2.1.18                    | RE-CHARGE TIME FOR BATTERY.....  | 31          |
| <b>3.0</b>                | <b>MECHANICAL CONFIGURATION.....31</b>                                   |             |
| 3.2                       | INTERNAL BATTERY OPTION.....   | 32          |
| 3.3                       | EXTERNAL BATTERY CABINET OPTION.....                                     | 32          |
| 3.4                       | BATTERY SYSTEM.....  | 32          |
| <b>4.0</b>                | <b>INSTALLATION – refer to “installation manual section page 16-18”.</b> |             |
| <b>5.0</b>                | <b>INTRODUCTION TO B.B.S. UNIT..... 34</b>                               |             |
| 5.1                       | INTRODUCTION.....  | 34          |
| 5.2                       | SAFETY.....  | 35          |
| 5.3                       | FRONT PANEL.....   | 36          |
| 5.4                       | SYSTEM SCHEMATIC.....  | 37          |
| <b>6.0</b>                | <b>THEORY OF OPERATION..... 39</b>                                       |             |
| 6.1                       | DETAILED CIRCUIT DESCRIPTION.....  | 40          |
| 6.1.1                     | BY PASS SWITCH ASSEMBLY.....   | 40          |
| 6.1.2                     | POWER TRANSFER RELAY.....  | 40          |
| 6.1.3                     | BATTERY CHARGE INVERTER .....  | 40          |
| 6.1.4                     | SURGE SUPPRESSOR .....   | 40          |
| 6.1.5                     | MICROPROCESSOR CONTROL BD .....  | 41          |

## TABLE OF CONTENTS (CONTINUED):

|             |   |           |
|-------------|---|-----------|
| 6.1.6       | DISPLAY BOARD .....   | 42        |
| 6.1.7       | MONITORING/TIME BOARD.....  | 42        |
| <b>7.0</b>  | <b>START UP AND TURN ON STEPS / SHUT DOWN STEPS.....</b>            | <b>44</b> |
| 7.1         | ALARM .....   | 44        |
| 7.1.1       | TO START UNIT STEPS.....  | 44        |
| 7.1.2       | TO PERFORM SELF TEST.....   | 44        |
| 7.1.3       | BATTERY CHARGER BAR GRAPH.....                                      | 45        |
| 7.1.4       | COLD START.....   | 45        |
| 7.1.5       | SHUT-DOWN MODE.....   | 45        |
| 7.1.6       | ALARMS.....   | 45        |
| 7.2         | SHUT DOWN STEPS.....  | 46        |
| <b>8.0</b>  | <b>MAINTENANCE AND TROUBLE SHOOTING.....</b>                        | <b>47</b> |
| 8.1         | PREVENTIVE MAINTENANCE.....   | 48        |
| 8.2         | TROUBLESHOOTING.....  | 50        |
| <b>9.0</b>  | <b>PARTS LIST.....</b>  | <b>51</b> |
| <b>10.0</b> | <b>BATTERY.....</b>   | <b>52</b> |
| <b>11.0</b> | <b>STORAGE.....</b>   | <b>52</b> |
| <b>12.0</b> | <b>ASSEMBLY DRAWING, PICTURES, BATTERY CONNECTION DIAGRAM... 53</b> |           |
|             | Figure 5: TOP CHOICE Unit Assembly dwg / Part list.                 |           |
|             | Figure 6: Battery charger curve.                                    |           |
|             | Figure 7: Battery connection diagram                                |           |
|             | Figure 8: TOP CHOICE unit / PTR / MBS front view.                   |           |
|             | Figure 9: TOP CHOICE External cabinet with batteries arrangement.   |           |
|             | Figure 10: Complete installed interconnection diagram schematics.   |           |
| <b>13.0</b> | <b>SCHEMATIC DIAGRAMS.....</b>                                      | <b>58</b> |
| A.          | CONTROL BOARD   |           |
| B.          | POWER BOARD   |           |
| C.          | SIGNAL RELAY AND AC START   |           |
| D.          | SYSTEM SCHEMATIC DIAGRAM  |           |
| E.          | TOP CHOICE / MANUAL BYPASS / POWER TRANSFER REALY.                  |           |

## 1.0 GENERAL DESCRIPTION

The Crucial Power, IPC-CALTRANS Model, P/N CT.75A0100N1-00 provides conditioned AC power to a critical load and assures continuity of power during primary power outages for up to two hours. Henceforth, the system shall be referred to interchangeably as TOP CHOICE (Battery Back-up System) along with UPS (Uninterruptible Power Supply) in this manual.

1.1.1 The system consists of a temperature controlled battery charger, a chopper, an inverter, manual bypass, and fail-safe bypass relay.

1.1.2 Basic system description:

The battery charger converts the input AC power to DC into order to provide temperature controlled charging current to the battery bank and supplies a DC source to the up-chopper. A 30 Amp power relay contact provides the AC power to the critical load. The up-chopper raises the battery DC voltage to the proper DC level, which powers the inverter. In the event of an input power disturbance such as power failure or if the input AC voltage is out of input voltage range, the inverter converts the DC power stored in the battery bank to AC and regulates the AC to provide conditioned power to the critical load. The inverter operates from battery if charged with or without the battery charger operating. Should the batteries cease to be available, the unit will shutdown upon an input failure.

1.1.3 Cooling:  
Fans located in the rear of the unit accomplish cooling. There is another AC fan inside the unit near the output transformer.

1.1.4 Battery Polarity:

**Caution:** The battery bank must be connected with proper polarity or the equipment will be damaged. The positive battery terminal (Anderson connector) is red in color and marked (+) while the negative battery terminal is black in color and marked (-).

## 2.0 GENERAL CHARACTERISTICS/SPECIFICATION: INPUT / OUTPUT

### 2.1.1 INPUT SPECIFICATION:

|                   |  |
|-------------------|--|
| VOLTAGE           | 120 VAC, 100-130 VAC ( $\pm 2$ VAC) SINGLE PHASE, 3 WIRE                                     |
| FREQUENCY CURRENT | 60Hz $\pm 3$ Hz  |
| BATTERY VOLTAGE   | 48 VDC (4 CELLS x 12 VDC BATTERY) 65 AH<br>FLOATING 54 VDC LOW DISCHARGE 41.5 VDC $\pm$ 0.5V |

### 2.1.2 OUTPUT SPECIFICATION:

|                           |   |
|---------------------------|---|
| VOLTAGE                   | 120 VAC, 100-130 VAC ( $\pm 2$ VAC) @ input power<br>AC normal 125 VAC with battery power |
| FREQUENCY CURRENT         | 60Hz $\pm 3$ Hz   |
| HARMONICS TOTAL HARMONICS | LESS THAN 3%  |

- 2.1.3 **Battery Backup Time:** The TOP CHOICE provides a minimum two (2) hours of full run-time operation for an "LED-only" intersection.
- 2.1.4 **Transfer Time:** The maximum transfer time from loss of utility power to switchover to battery backed inverter power is 65 milliseconds.
- 2.1.5 **N/O & N/C Contacts (3 Sets):** The TOP CHOICE provides 3-sets of normally open (NO) and normally closed (NC) single-pole double-throw (SPDT) relay contact closures, available on a panel-mounted terminal block, rated at a minimum 120V / 1A and labeled so as to identify each contact. For typical configuration, see figure 3(b).
- o The first set of Normally Open (NO) and Normally Closed (NC) contact closures are energized whenever the unit switches to battery power. Contact is labeled "ON BATT".
  - o The second set of NO and NC contact closures are energized whenever the battery approaches approximately 40% of remaining useful capacity. Contact is labeled "LOW BATT".
  - o The third set of NO and NC contact closures are energized two hours after the unit switches to battery power. Contact is labeled "TIMER".
- 2.1.6 **Operating Temperature:** The TOP CHOICE' operating temperature range is -37°C to +74°C.
- 2.1.7 **Transfer Relay And Manual By-Pass Switch:** Both the Power Transfer Relay and Manual Bypass switch are rated at 240 VAC /30 amps.
- 2.1.8 **Temperature Compensated Battery / Charger:** The TOP CHOICE is a temperature compensated battery charging system. The charging system compensates over a range of 2.5-4.0mV/°C per cell.

- 2.1.9 **Temperature Sensor:** The inverter/charger of the TOP CHOICE is provided with an external temperature sensor. It comes with 2 meters (6'6") of wire.
- 2.1.10 **Battery Temperature 50°C:** When the battery temperature reaches 50°C ±3°C the batteries are disabled.
- 2.1.11 **INPUT VOLTAGE 100-130V RANGE** TOP CHOICE will bypass the utility line power whenever the utility line voltage is outside of the following voltage range: 100VAC to 130VAC (±2VAC).
- 2.1.12 **OUTPUT VOLTAGE WITH BATTERY POWER:** When utilizing battery power, the TOP CHOICE produces an output voltage between 110 VAC and 125 VAC, pure sine wave output, ~3% THD, 60Hz ±3Hz.
- 2.1.13 **Cabinet Compatibility:** The TOP CHOICE is designed to be compatible with Caltrans Model 332 Cabinets, Model 170 Controllers, Model 2070 Controllers and cabinet components for full time operation.
- 2.1.14 **Restoring Utility At 105vac ±2v:** When the utility line power has recovered from a low voltage condition of 98VAC (or below) to a level above 105VAC ±2VAC for more than 30 seconds, the TOP CHOICE comes out of battery backup mode and returns to utility line mode.
- 2.1.15 **Restoring Utility At 125vac ±2v:** When the utility line power has been restored from a high voltage condition of 132 VAC to a level of 125VAC ±2VAC for more than 30 seconds, the TOP CHOICE comes out of battery backup mode and returns to utility line mode.
- 2.1.16 **No Feedback To Utility Source:** The TOP CHOICE is designed to protect the cabinet and the utility service from feedback.
- 2.1.17 **Power Transfer Relay:** In the event of inverter/charger failure, battery failure or complete battery discharge, the power transfer relay reverts to the NC state, where utility line power is reconnected to the cabinet.
- 2.1.18 **Re-Charge Time For Battery:** The recharging of the battery takes no longer than twenty (20) hours from "protective low-cut-off" to 80% or more of full battery charge capacity.

### **3.0 MECHANICAL CONFIGURATION:**

- 3.1.1 Inverter / Charger Unit is rack or shelf-mounted as shown in figure
- 3.1.2 Power transfer relay and manual bypass switch are mounted on the 332 Cabinet standard Electronic Industries Association (EIA) rail.
- 3.1.3 All interconnect wiring provided between power transfer relay, bypass switch and cabinet terminal service Block are a minimum of 2 meters (6'6") of #10 AWG wire.
- 3.1.4 Relay contact wiring provided for each set of NO/NC relay contact closure terminals are 2 meters (6'6") of #18 AWG wire.

- 3.1.5 Manual. Bypass switch is interconnected with Model 332A Cabinets in order to ensure interchangeability between all TOP CHOICE manufacturers.
- 3.1.6 All necessary hardware for mounting (shelf angles, rack, etc) is included in the TOP CHOICE. A minimum of 6 bolts / fasteners secure swing trays to the 332.
- 3.1.7 Cabinet standard EIA 482.6mm (19") rack. All bolts / fasteners and washers usage characterized as noted below.
- Screw type: Pan Head Philips machine screw.
  - Size and Thread pitch: 10-32
  - Material: 18-8 stainless steel (Type 316 stainless steel is acceptable as an alternate)
  - Washer: Uses one flat washer (18-8 stainless steel) under the head of each 10-32 screw.
  - As long as screws are properly tightened, then lock washers are unnecessary.
  - Number of screws per swivel bracket, minimum: 6 screws (minimum) per Spaced evenly along bracket, with one screw near each end.

## 3.2 INTERNAL BATTERY OPTION

- 3.2.1 The complete TOP CHOICE, including batteries, will fit inside a typical, fully equipped Caltrans Model 332 Cabinet that includes one Model 170 or 2070 Controller.
- 3.2.2 Mounting method is shelf-mount, swing tray mount or combination of either. Front mounted available rack space is 3U or approximately 152.4mm (6"). For additional space, see figure 2 - TOP CHOICE Mounting Diagram.
- 3.2.3 Batteries mounted below the controller shelf are swing-tray mounted. Batteries are shelf-mounted in the area behind controller (provided that the shelf and batteries do not interfere with controller unit and C12 plug).

## 3.3 EXTERNAL BATTERY CABINET OPTION

- 3.3.1 The inverter/ charger power transfer relay and manually operated bypass switch fit inside a typical fully equipped Caltrans Model 332 Cabinet that includes one Model 170 or 2070 controller.
- 3.3.2 Batteries are to be installed in a NEMA 3R rated cabinet mounted to the side of the Model 332 Cabinet  
See Battery schematic 6120-777 for Battery connection.
- 3.3.3 Batteries are mounted on individual shelves.
- 3.3.4 The external battery cabinet is ventilated by way of louvered vents (2), filters, and one thermostatically controlled fan.

- 3.3.6 The TOP CHOICE with external battery cabinet comes with all bolts, conduits and bushings, gaskets, shelves, and hardware needed for mounting.

## 3.4 BATTERY SYSTEM

- 3.4.1 Individual batteries are 12V type, 65 amp-hour maximum. These can easily be replaced and are commercially available off the shelf.
- 3.4.2 4 to 8 batteries are used for the TOP CHOICE. These have a cumulative minimum rated capacity of 240 amp-hours.
- 3.4.3 The batteries are deep cycle, sealed prismatic lead-calcium based AGM / VRLA (Absorbed Glass Mat / Valve Regulated Lead Acid.)
- 3.4.4 The batteries are provided with appropriate interconnect wiring, corrosion-resistant mounting trays and brackets appropriate for the cabinet into which they will be installed.
- 3.4.5 Batteries indicate maximum recharge data and recharging cycles.
- 3.4.6 Battery interconnect wiring is via modular harness. Batteries are shipped with positive and negative terminals pre-wired with red and black cabling that terminates at a typical power pole style connector. Harness is equipped with mating power pole style connectors for batteries and a single insulated plug style connector going to the inverter/ charger unit harness. This allows batteries to be quickly and easily connected in any order. These connectors are keyed and wired to ensure proper polarity and circuit configuration.
- 3.4.7 Battery terminals are covered and insulated so as to prevent accidental shorting.

## 5.0 INTRODUCTION OF THE ACTUAL B.B.S UNIT.

### 5.1 INTRODUCTION

This product is line interactive UPS with the newest technology incorporating powerful functions. Its operation is based on microprocessor control, with utility power connected; charging is ongoing with no need to switch ON the UPS and at back-up mode. When the battery needs replacement, an indicator comes on and a cyclic self-testing function verifies both the operation of the UPS and the condition of the battery.

In addition, the TOP CHOICE provides advanced 3 NO/NC signals as "Battery ON", "Low Battery" and an advanced large Surge Suppressor which can handle IEEE-C3 surge standard.

Note: There is no guarantee that interference from radio / TV will not occur in particular installations and areas. If it is suspected that this UPS causes radio or television interference, then this can be verified by turning the UPS off and on. If such is the case that the unit is causing interference, then the user is encouraged to try to correct the interference by one or more of the following measures:

- Connect the equipment to an outlet on a circuit different than the outlet connected to the receiver.
- Increase the separation between the equipment and the receiver.
- Reorient the receiving antenna.

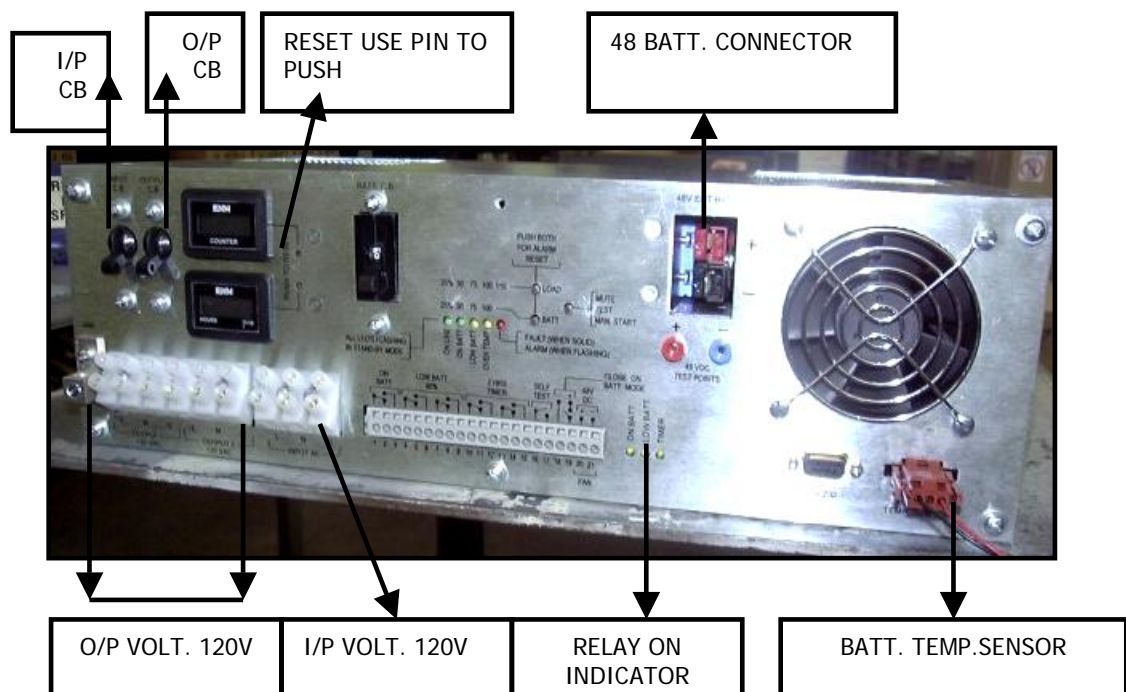

FIGURE1

## 5.2 SAFETY

### **CAUTION !!!**

- To reduce the risk of electric shock, disconnect the UPS from the main supply before installing a computer interface signal cable. Reconnect the power cord only after signaling interconnections have been made.
- There is no internal battery in this unit.
- The right way to de-energize the UPS properly in an emergency is to move the I/O Circuit Breakers to the OFF position and disconnect the power cord from the main supply.
- The socket-outlet installs near the equipment and is easily accessible.
- **Attention: Hazardous through electric shock:** Even with disconnection a hazardous voltage may still exist and present a danger. So extreme caution should be taken in handling. The battery supply should be disconnected at the plus and minus pole when maintenance / service work inside the UPS is performed.
- **Do not dispose of batteries in fire. The battery may explode.**
- **Do not open or mutilate the battery. Released electrolyte is harmful to the skin and eyes.**
- **A battery can present a risk of electric shock and high short circuit current. The following precaution should be observed when working on batteries. Battery pack has 3 independent packs for two hours run time.**

**Remove watches, rings or other metal objects.  
Use tools with insulated handles.**

**Caution: Risk of electric shock. Do not remove cover. No user serviceable parts are inside. Refer servicing to qualified service personnel.**

**Warning: To reduce the risk of fire, replace only with the same type and rating of fuse.**

**Warning: To reduce the risk of fire. or electric shock, install in temperature and humidity controlled indoor area that is free of conductive contaminant.**

## 5.3 FRONT PANEL

- A. **Mute test manual start button:** With the UPS plugged in, it is sometime necessary to press the ON /TEST button to turn the UPS on and power the loads.
- B. **“OVERLOAD” Indicator (RED LED).**
- C. **“BACK-UP” Indicator (GREEN LED):** The LED illuminates when the UPS is running with battery power source.
- D. **“REPLACE BATTERY” Indicator (RED LED).**  
Note: when replace the battery, disconnect the battery from the unit. Replace all.
- E. **“LINE NORMAL” Indicator (GREEN LED).** The LED illuminates when the line input voltage is normal with UPS was not start.
- F. **LOAD BAR GRAPH:** This display shows the power being drawn by the load.
- G. **POWER BAR GRAPH:** battery charge /line voltage: the display shows the present battery charge as a percentage of battery capacity
- H. **Battery Event Counter** — Counts the number of transfer to battery. | Battery Run Timer
- I. **External Battery Pack** — use only factory supplied or authorized connecting cable for external battery
- J. **AC input Power Cord.**
- K. **Aux. Contact N/O & N/C batteries (for battery run two hrs. timers, and low battery, and battery run).**
- L. **AC input Circuit Breaker.**
- M. **Battery Circuit Breaker.**
- N. **Thermistor Sensor Connector.**

## 5.4 System Schematic:

(See Schematic 6120-763)

FIGURE 2

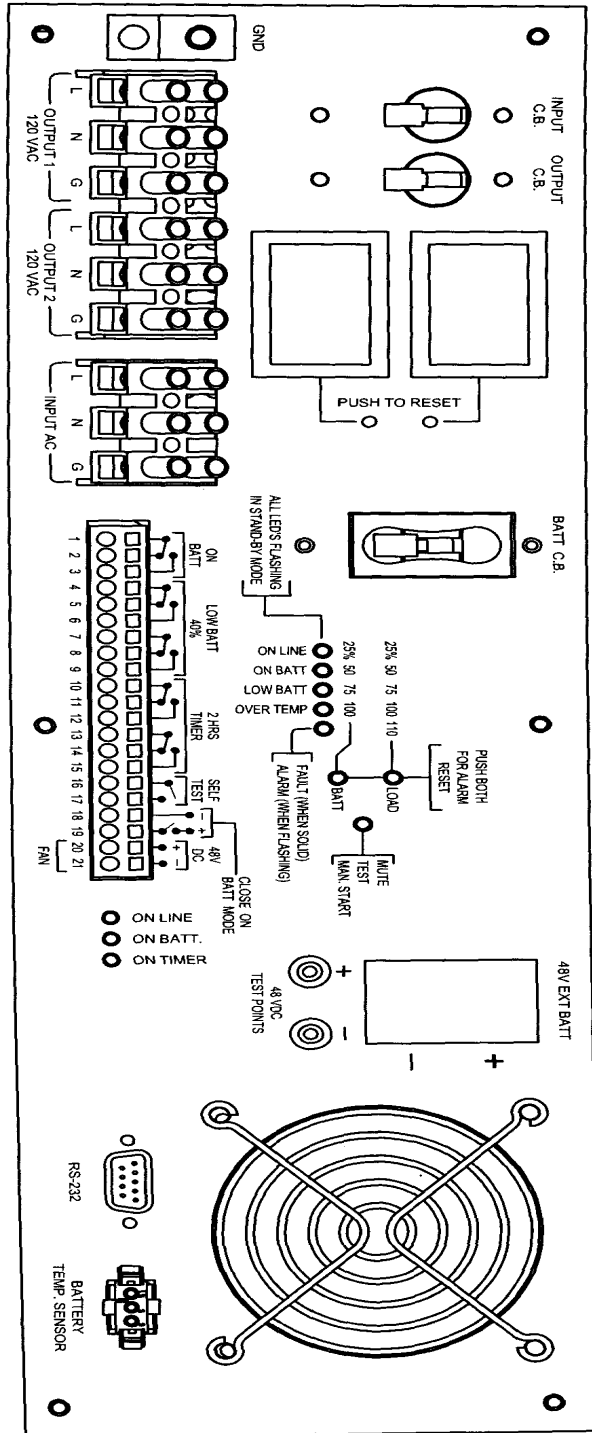

## 6.0 THEORY OF OPERATION

### GENERAL

The TOP CHOICE is shown as a functional block diagram in Figure 1 in this document. The unit consists of a battery / charger/ inverter section, a power transfer relay, a manual bypass switch, a microprocessor PC board, display board, a TOP CHOICE monitoring board as well as other options and all the hardware and interconnect wiring that are necessary for operation. System schematic diagram is found in FIGURE 11 within this document.

The commercial power line is connected to the input terminal block and bypass switch. The bypass switch has two options for manual mode and auto mode. When the bypass switch is in the manual mode, the input AC power is supplied directly to the critical load, which permits changing of batteries or maintenance activities.

When the bypass switch in the auto mode position, then the input AC power is connected to the battery charger and power relay and supplies input AC power to the load prior to turning on the unit.

To turn on the unit, first close CB 1 (input circuit breaker) and then push the "ON" switch. After the initialization of the microprocessor takes place, the output voltage is transferred to the critical load through the power relay, which is now energized because the unit output AC is available.

This unit's output AC conditions the output and puts out an output voltage which is the same level as the input AC power as long as the input voltage values are within 130VAC  $\pm$ 2V and 100 VAC  $\pm$ 2V. When the input AC voltage is out of the unit's maximum and minimum specification range, it transfers automatically to battery power within 65 milliseconds for any condition. At that point, the battery supplies the AC output to the load through its inverter and is capable of sustaining power for a minimum two hours when loaded up to 700 Watts. The TOP CHOICE with its remote sensors through a DB9 and terminal block provides 3 sets of normally open (NO) and normally closed (N/C) contacts along with a common for battery run 40% battery remaining, and the end of two hours from battery power.

The output of the inverter is a pure sine wave with less than or equal to 3% total harmonic distortion and at a frequency of 60Hz  $\pm$ 3Hz. If the inverter fails for any reason, the power relay within the unit will be de-energized and will supply the load AC power through a normally closed contact. Under these circumstances, should the input power disappear, the unit will shut down. The temperature inside the cabinet is continually sensed at the battery charger and a temperature compensated DC output from the battery charger is produced over a temperature range of -40°C to 50°C. The battery charger turns off when the temperature exceeds 50°C  $\pm$ 3°C

## 6.1 DETAILED CIRCUIT DESCRIPTION (Refer to functional Block Diagram, [figure 3](#))

### 6.1.1 Bypass Switch Assembly

The bypass switch has two positions, one for manual mode and the other for auto mode

The switch position should be in the auto mode position all the time unless the TOP CHOICE is down for repair or maintenance. This switch is rated 240 VAC, 30Amp. This assembly is a self-contained box with a bypass switch and a terminal block.

### 6.1.2 Power Transfer Relay Assembly.

This power relay is for utilized for the purpose of bypassing the inverter in the event of inverter failure, battery failure or complete battery discharge. The power transfer relay is dc-energized using a normally closed contact to transfer power to utility when utility line power is available.

This relay will provide the fail-safe mode of operation that increases the total mean time before failure for the operation of the total system. The relay is rated 30 Amp, 240 VAC.

### 6.1.3 Battery Charge and Inverter Section.

The battery charger generates the DC output to charge the batteries and is rated 3.5 Amps at 54 VDC. The battery charger circuits are built into the motherboard. The inverter circuit generates the charging voltage with 3.5 Amp current limit capability as constant voltage and constant current sources.

The inverter becomes a battery / charger whenever the input AC power voltage is within the specification, that is, from 100VAC to 130VAC.

By sensing the temperature of the cabinet (temperature sensor is located cable outside of inverter case) through thermal-sensing devices, the DC output voltage from the battery / charger is continuously controlled in accordance with the curve shown in Figure 6 (from -40°C to 50°C). At 50°C and above, the battery / charger will be turned off automatically to prevent overcharging. The output of battery charger has very low ripple content as a result of the high switching frequency.

### 6.1.4 Surge Suppressor Section.

This surge suppressor is rated 300 VAC, at maximum surge current, single pulse, 8/20 microsecond of 18K Amp. And surge energy capacity is 1450 Joules. This multiple metal oxide varistors meets European spacing requirements, EN60335, and ANS / IEEE C62.41 and C62.11 wave-shapes, L-N

## 6.1.5 **Microprocessor Control Board Section.**

The microprocessor functions include not only self tests and the UPS' operation, but also serves in the monitoring functions (of the input AC power conditions) and generates all alarms and conditions of UPS.

It transfers power to the battery source when the AC input is in out of range of condition, from when the input AC is below 100VAC or is above 130 VAC. When the AC line power has been restored at above 105 VAC  $\pm$ 2VAC or at below 125VAC  $\pm$ 2VAC for more than 30 seconds, it transfers the unit back to the input AC power.

This re-transferring command signal is controlled by precise microprocessor software located on the board.

## 6.1.6 **Display Board Section.**

This display board is mounted on the front panel and there are several LEDs to indicate the UPS status.

- A. **On test switch button:** The ON / TEST button when pressed turns on the UPS and provides power to the load. This switch also activates the self-test and displays line voltage.
- B. **Overload (Red LED):** This LED lights when the load exceeds the UPS's rating.
- C. **Backup (Green LED):** The LED illuminates when the UPS is running from battery source.
- D. **Replace battery (Red LED):** The LED illuminates with the UPS battery is no longer useful.
- E. **Load Bar Graph:** The display shows the approximate load level.
- F. **Battery Voltage Bar Graph:** This displays the present approximate DC voltage on the battery.

## 6.1.7 **Monitoring / Time Board Section.** This board generates the user's contacts with 3 sets of normally open (NO) and normally closed (NC), Single Pole Double Throw (SPDT) Relay.

By sensing the condition of UPS from the Microprocessor Board and the Display Board, the 3 sets of NO and NC contacts are provided to the DB9 as follows:

|          |                        |
|----------|------------------------|
| DB9-Pin1 | Normally open          |
| DB9-Pin2 | Normally closed        |
| DB9-Pin5 | Common for battery-on  |
| DB9-Pin6 | Normally open          |
| DB9-Pin7 | Normally closed        |
| DB9-Pin5 | Common for low battery |
| DB9-Pin3 | Normally open          |
| DB9-Pin4 | Normally closed        |

DB9-Pin5

Common for the end of 2 hours battery run.

## 6.1.7 COMMUNICATION VIA RS232

RS232 interface port is an option.

Not required for TOP CHOICE system

However can be an option to do following tasks.

- 6.1.7.1 When the front panel's DB-9 (RS-232) female connector is connected to a PC with window 3.1, 9x, or terminal emulation software, the unit can be remotely monitored, controlled and calibrate with RS-2323 ASCII commands.

Note: The PC should be local and within 50 feet of maximum distance, a limitation of communication, RS-232, port.

### 6.1.7.2 DB-9 connector's pin

Pin – assignments are as follow

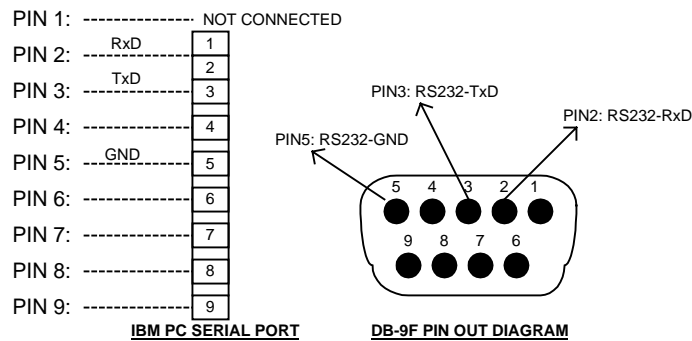
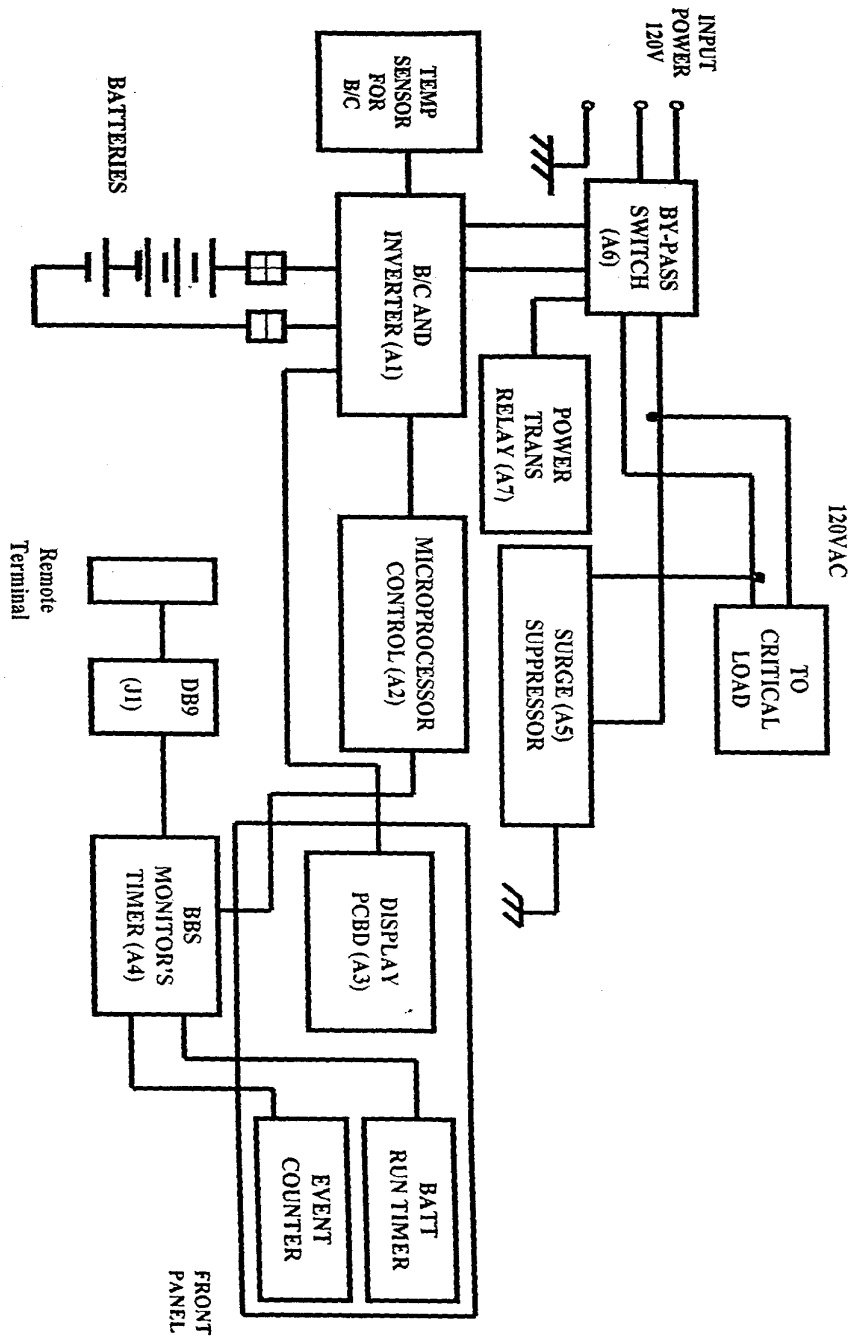

FIGURE 3



## 7.0 START-UP AND TURN ON STEPS / SHUT DOWN STEPS

### 7.1 TO START UNIT – MAKE SURE THE MBS ON “ AUTO POSITION” IN MBS / PTS ASSY.

#### 7.1.1 STEPS:

STEP 1 – CLOSE INPUT CIRCUIT BREAKER (CB1)

STEP 2 – CLOSE OUTPUT CIRCUIT BREAKER (CB2)

STEP 3 – CLOSE BATTERY CIRCUIT BREAKER (CB3)

UNIT WILL BE TURNED ON IN ABOUT 30 SECONDS.

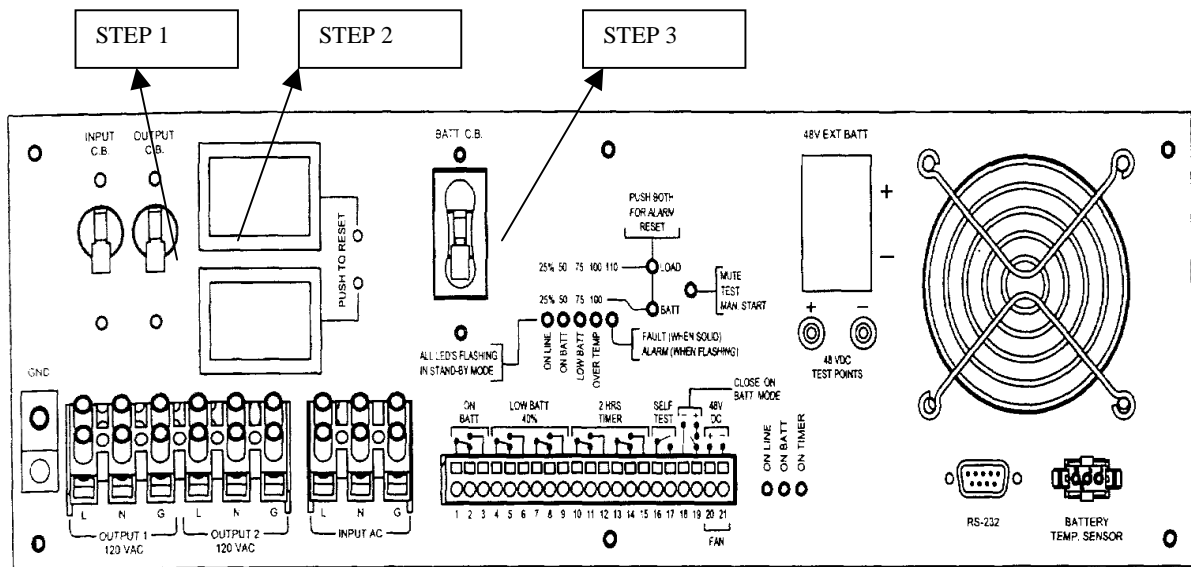

7.1.2 **To perform self-test:** Use the self-test to verify both the operation of the UPS and the condition of the battery. In normal utility power, short terminal 16 & 17 and hold for 2 seconds. The UPS performs a self-test function for about 1 minute. During the self-test, the UPS operates in back-up mode.

Note: During the self-test, the UPS briefly operates the loads on battery and the on-battery LED comes on.

If the UPS fails the self-test, it immediately returns to on-line operation. The indicator goes back to same status indication as before.

If the UPS fails the self-test, it immediately returns to on-line operation and illuminates the replace battery LED. The loads are not affected. Recharge the battery overnight and perform the self-test again. If the replace battery LED is still on, consult with factory or ask our nearest dealer to replace battery.

- 7.1.3 **Battery Charge Bar Graph:** The 5-LED display shows the UPS' battery's status relative to the percentage of the battery capacity. By pushing the bottom button and holding it, the display shows battery voltage level. When only two LED lights are lit, the battery can supply less than two minutes of run time for the load. Depressing the top button and holding yields the load level.
- 7.1.4 **Cold Start:** When the UPS is off and there is no utility power, use the cold start feature to apply power to the loads from the UPS's battery. Press manual start button and hold one second. The unit will start-up
- 7.1.5 **Shut-down mode:** In shutdown mode, the UPS stops supplying power to the load and waits for the return of utility power. If there is no utility power present, external devices (e.g., servers) connected to the computer interface can command the UPS to shutdown. This is normally done to preserve battery capacity after the graceful shutdown of protected servers. The UPS will scroll the front panel indicators sequentially in shut-down mode.

**Note: During shutdown, sometimes, the front fan keeps running for a few minutes and stops and also the front panel indicator will keep flashing until battery voltage drop to 35V.**

## 7.1.6 ALARMS

- A. **"BACK-UP (slow alarm):** When in BACK-UP mode, the **"On Batt"** illuminates and the ON Batt relay indicates **ON** also. The AC ON changed when the UPS returns, to LINE NORMAL operation, AC on LED indicator will be on.
- B. **"LOW BATTERY":** In BACK-UP mode, when the battery energy runs low, the **"LOW BATT"** is turned on. Also **"LOW BATT"** relay indicates **ON**.

**"OVERLOAD":** When the UPS is overloaded (the connected loads exceed the maximum rated capacity) the UPS sends out a continuous alarm that warns of an overload condition. Disconnection of non-essential load equipment is recommended to eliminate an overload.

- C. **"FAULT":** When the UPS signals **"FAULT"**, an indicator illuminates that the UPS is not operating properly. When UPS is working under overload condition, that is the connected loads exceed the maximum rated capacity, the UPS emits a continuous alarm to warn of the overload condition. In order to protect the unit and the loads, the UPS will automatically shutdown. It is recommended that any nonessential equipment be disconnected from the UPS to eliminate the overload and the alarm condition.

## 7.2 SHUT DOWN STEPS

### SHUT DOWN STEPS



“DANGER WARNING”

Even when the unit is off, there is potentially dangerous voltages within the unit due to the batteries and line power connection.

Extreme care must be taken when working within the TOP CHOICE system

#### 1.3.2.3 UPS control unit shut down

- Step 1 – Turn off the battery circuit breaker
- Step 2 – Turn off the input circuit breaker
- Step 3 – Turn off the output circuit breaker
- Step 4 – Unplug the J2-connector from the unit.
- Step 5 – Disconnect PTS control signals from TB-18 and TB-19.
- Step 6 – Disconnect the input and output wires from TB1 & TB2 of unit.  
And isolate the wires individually using electrical tape.
- Step 7 – Remove or perform maintenance on the UPS control unit.

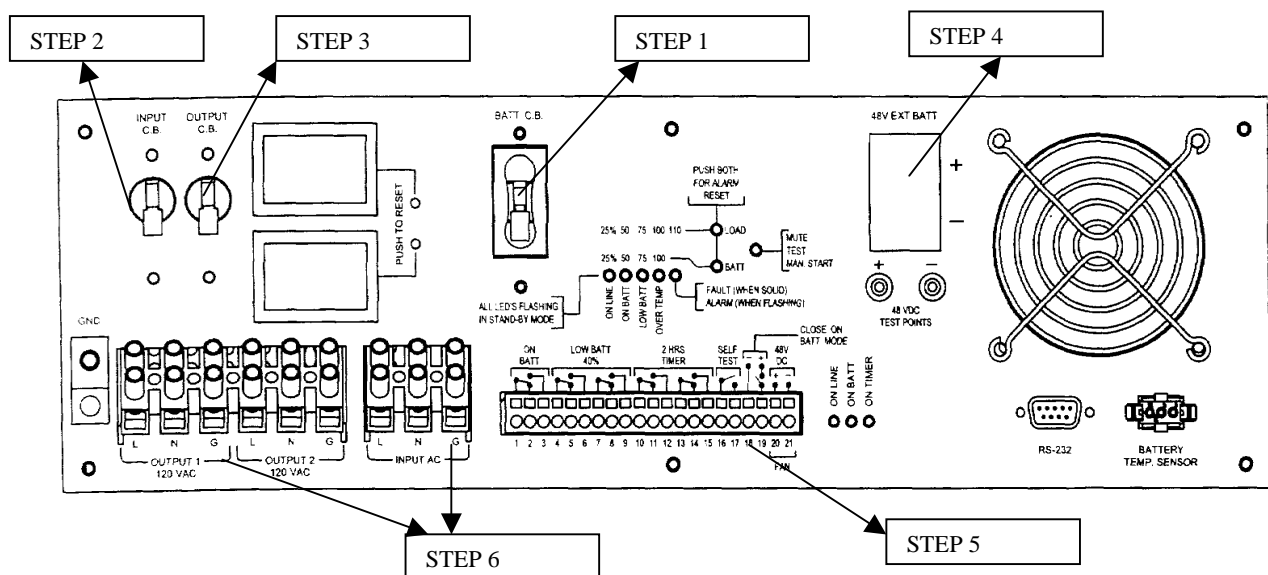

### “WARNING”

Since this TOP CHOICE unit is off line unit and has manual bypass switch and power transfer switch functions, the critical load is still supporting through power transfer switch due to UPS control unit disconnection.

If desire, switch MBS to manual position for making sure there will be no power interruption during the shut down unless the main input power to TOP CHOICE is

disconnected.

## 8.0 MAINTENANCE AND TROUBLE SHOOTING

- The TOP CHOICE (Battery Backup System) is designed to only need minimum maintenance through its life.
- The only required periodic maintenance is to clean the unit and vacuum the ventilation intake.
- The battery connections should be checked periodically for the proper torque to insure that the connections are good. Refer to torque table below.
- The unit's electronics require no maintenance.

**ALL TERMINAL CONNECTIONS SHALL BE TORQUED TO VALUE IN TABLE BELOW.**

**TORQUE TABLE**

| SIZE OF WIRE TAT IS TO BE USED FOR CONNECTION OF THE UNIT |                 | <u>TIGHTENING TORQUE POUND – INCHES (N-m)</u> |                           |   |                   |
|---|-----------------|---|---------------------------|---|-------------------|
|   |                 | SLOTTED HEAD no. 10 or LARGER                 |                           | HEXAGONAL HEAD – EXTERNAL DRIVE SOCKET WRENCH |                   |
| AWG / kcmil   | mm <sup>2</sup> | SLOT WIDTH <0.47" & <1/4"                     | SLOT WIDTH >0.47" & >1/4" | SPLIT-BOLT-CONNECTOR                          | OTHER CONNECTIONS |
| 18-10   | 0.82-5.3        | 20 (2.3)                                      | 35 (4.0)                  | 80 (9.0)                                      | 75 (8.5)          |
| 8   | 8.4             | 25 (2.8)                                      | 40 (4.5)                  | 80 (9.0)                                      | 75 (8.5)          |
| 6-4   | 13.3-21.2       | 35 (4.0)                                      | 45 (5.1)                  | 165 (18.6)                                    | 110 (12.4)        |

## 8.1 PREVENTIVE MAINTENANCE

The battery is a component that degrades with time in service.

The Cell/Unit internal resistance impedance will increase. The actual life achieved will be a function not only of the Battery design but also of the Application.

To achieve the optimum life of the battery and avoid problems **Battery Maintenance** should be considered.

### Battery Maintenance Testing & Specifications

#### Battery Specifications

- Battery Impedance - The battery impedance value is measured @ 25° C. This value is for new batteries at full state of charge, on open circuit at a frequency of 30 Hz. Battery Impedance is about 8.0 milliohms.
- Float Voltage - The specified float voltage "wind "is.2.25 ~ 2.30 V.P.C. @ 25°C.This Value will help in reducing recharge times and keeping the batteries at the highest state of charge.
- Recommended Procedures  
These methods are designed to be used on a battery system installed for a minimum period of 6 month, in a steady state of Float condition and not under conditions of high current recharge or discharge.
- Measure Float Voltage
- When the Low Battery LED is" ON" over 24 hours test system, remove the Battery Tray Plug from the battery jack on the Electronic Tray, so readings can be taken.
- Measure and record system voltage directly across the battery plug.
- If the battery system is determined to be low voltage system after 24 hours of charging the system voltage will be only 3% low, remove and replace the Battery.
  - Battery Servicing
- Measure and record a 10% sample of individual battery temperatures at the negative terminal post.
- Identify batteries that are greater than 3° C above ambient from the calculated average. If no external causes for higher battery temperatures are noted.
- Check that the filters are clean and Fans are operational.
- If no charge is noted, remove and replace the Battery.
- If no charge is noted, remove and replace the Battery.

- Visual Inspections
- Examine batteries for any abnormalities in end wall bulge, post leakage, cover to cells leakage, etc.
- Identify any end wall bulges that exceed 1/2 inches compared to the other batteries in tray.
- Load Testing
- Load Testing shall only be performed as a bench test.
- While on open circuit, place 100 amp load across each battery for a period of 30 seconds.
- Measure and record end of discharge (E.O.D.) voltage at 30 seconds.
- Calculate average and compare results against value of 10.95
- For type 65AH battery @ 30 Seconds and 100 amp load.
- If calculated average E.O.D. of group is observed as being normal, identify and replace individual batteries with values that are 10% less than the group average.
- General Equipment Requirements.
- Digital voltmeter- 3 1/2 digit, minimum 0.25% accuracy.
- Load tester (100 amps) with digital voltage readout, minimum 0.25% accuracy.
- Thermometer- thermocouple, contact type, 1 °C accuracy.
- Battery Date Coding.
- The manufacturer stamps the Negative terminal post of the battery, with the month and year date code.
- Shelf life is based on normal storage temperature conditions, 66 °F ~ 90 °F, and requires recharging every 6 months from the last full charge date.

**!WARNING!**

**BATTERY SHELF TIME, WHEN STORED UNDER TEMPERATURE CONDITIONS of 66 °F ~ 90 °F, is FIVE ( 5 ) MONTHS MAXIMUM AFTER THE SHIP DATE.**

**BATTERY MUST BE RECHARGED AFTER THIS DATE OTHERWISE THEY WILL BE DAMAGED.  
THE SHIP DATE IS PART OF THE SERIAL NUMBER,**

## 8.2 MAINTENANCE AND TROUBLE SHOOTING

If the unit fails to perform a specific function, a listing on the next page shows typical problem symptoms, their causes and their solutions, starting with the most obvious and working systematically. If you cannot fix a particular problem, contact Crucial Power's Customer Service Department. By following this manual's guidelines, you will have many years of trouble free service.

| <u>SYMPTOM</u>   | <u>CAUSE</u>                                 | <u>REMEDY</u>   |
|--|--|---|
| TOP CHOICE DOES NOT TURN ON WHEN BATTERY CIRCUIT BREAKER IS TURNED ON.           | POWER ON CIRCUIT IS DISABLED                 | CONNECT LINE POWER AND RE-START<br>WAIT 5 MINUTES FOR THE POWER CIRCUIT TO RESET. |
|  | DEAD BATTERY                                 | CONNECT A KNOWN GOOD BATTERY  |
|  | BATTERY CIRCUIT BREAKER OFF.                 | TURN THE BATTERY CIRCUIT BREAKER ON   |
|  | FAULTY UNIT                                  | CONTACT VENDOR. SEE RENEWABLE PART 8.0  |
|  |  |   |
| ONLINE MODE DOES NOT COME ON   | NO LINE POWER                                | WAIT FOR LINE POWER<br>SEE THE UPSTREAM CIRCUIT BREAKER IS ON                     |
|  | LINE VOLTAGE TOO LOW                         | WAIT FOR VOLTAGE TO COME UP TO ACCEPTABLE LEVEL                                   |
|  | AC INPUT & OUTPUT CIRCUIT BREAKER TURNED OFF | TURN IT ON  |
| ON BATTERY MODE DOES NOT COME ON DURING A POWER FAILURE OR DURING A MANUAL START | LOW BATTERY CHARGE                           | CHARGE THE BATTERIES  |
|  | FAULTY UNIT                                  | CONTACT VENDOR. SEE RENEWABLE PART 8.0  |
| BACK-UP TIME IS LESS THAN RATED OR THERE IS A FLASHING LOW BATTERY LED           | BATTERY IS NOT FULLY CHARGED                 | FULLY RECHARGE THE BATTERY, THEN TEST BACKUP TIME                                 |
|  | DEAD BATTERY                                 | CONNECT A GOOD BATTERY  |
|  | BATTERY CIRCUIT BREAKER OFF                  | TURN THE BATTERY CIRCUIT BREAKER ON   |
|  | BATTERY FAILURE                              | CLEAN AND TIGHTEN BATTERY CONNECTIONS<br>CHECK BATTERY AND REPLACE IT NEEDED      |
|  | FAULTY UNIT                                  | CONTACT VENDOR. SEE RENEWABLE PART 8.0  |
| FAULT LED IS ON OR FLASHING  | CHECK FAULT CODES                            | CORRECT FAULT   |
|  |  | CONTACT VENDOR  |

### **“WARNING”**

Since this TOP CHOICE unit is off line unit and has manual bypass switch and power transfer switch functions, the critical load is still supporting through power transfer switch due to UPS control unit disconnection.

If desire, switch MBS to manual position for making sure there will be no power interruption during the shut down unless the main input power to TOP CHOICE is disconnected.

## 9.0 RENEWABLE PARTS LISTS:

| PARTS LIST |             |                          |     |
|------------|-------------|--------------------------|-----|
| ITEM       | OLP P/N     | DESCRIPTION              | QTY |
| 1          | 3050-234    | TEST POINT JACK-BLACK    | 1   |
| 2          | 3050-235    | TEST POINT JACK-RED      | 1   |
| 3          | 7020-610    | CONNECTOR MONTG PAD      | 1   |
| 4          | 7020-477    | ANDERSON CONNECTOR-BLACK | 1   |
| 5          | 7020-476    | ANDERSON CONNECTOR-RED   | 1   |
| 6          | 1000-051    | FAN                      | 1   |
| 7          | 1000-052    | FAN GUARD                | 1   |
| 8          | 7020-603    | 3 PIN CONNECTOR          | 1   |
| 9          | 7020-122    | DB9                      | 1   |
| 10         | 1550-062    | TIMER METER              | 1   |
| 11         | 1550-063    | COUNTER METER            | 1   |
| 12         | 7020-611    | 3 POLE TERMINAL BLOCK    | 1   |
| 13         | 7020-612    | 6 POLE TERMINAL BLOCK    | 1   |
| 14         | 1885-001    | GROUND LUG               | 1   |
| 15         | 2025-489    | INPUT/OUTPUT BREAKER     | 1   |
| 16         | 2025-557    | BATTERY BREAKER          | 1   |
| 17         | 1250-056    | SWITCH PCBD              | 1   |
| 18         | 1625-316-01 | DISPLAY PCBD             | 1   |
| 19         | 1250-057    | CONTROL PCBD             | 1   |
| 20         | 1250-059    | POWER PCBD               | 1   |
| 21         | 1450-1572   | POWER TRANSFORMER        | 1   |
| 22         | 5005-401    | SMT-TOP COVER            | 1   |
| 23         | 5005-401    | SMT-BASE                 | 1   |
| 24         | 5005-403    | SMT-FRONT COVER          | 1   |
| 25         | 5005-404    | SMT-CONNECTOR BRACKET    | 1   |

## 10.0 BATTERY

A. **Battery's life:** The UPS' battery's life is about 3-6 years under normal usage.

B. **Installation of battery cabinet and UPS (for AL and AXL models only):** Please follow the listed steps and provided illustration to complete the installation.

Turn off the UPS and remove the connector's metal cover from the back panel of UPS.  
Connect the battery cabinet's DC wire to the UPS and affix the metal cover via a screwdriver.  
Make sure the connections are reliable.

C. Turn on the UPS and plug the loads behind the UPS.

Caution: Do not dispose of battery in fire.

Caution: Do not attempt to open the battery.

Caution: The following precautions should be taken when replacing the battery Remove watches, rings, etc.

**For safety always use tools with insulated handles.**

D. Battery is supplied as separate item. Connection should be in series and DC voltage is 48 VDC (4x12 volt).

## 11.0 STORAGE:

A. **Storage condition:** In storing the UPS, keep it covered and in an upright position in a cool dry location, with its battery fully charged. Before storing, charge the UPS for at least four hours, remove any accessories in the accessory slot and disconnect any cables connected to the computer interface port to avoid unnecessary draining the battery.

B. **Extended storage:** During extended storage in environments where the ambient temperature is from 15°C to +30°C (+5 degree F to +86 degree F), charge the UPS' s battery every six months.

Extended storage: During extended storage in environments where the ambient temperature is from 30 degree to +45 degree C (+86 degree F to +113 degree F), charge the UPS' s battery every 3 months.

## 12.0 ASSEMBLY DWG, SCHEMATIC, BATTERY CONNECTION DIAGRAM

FIGURE 5

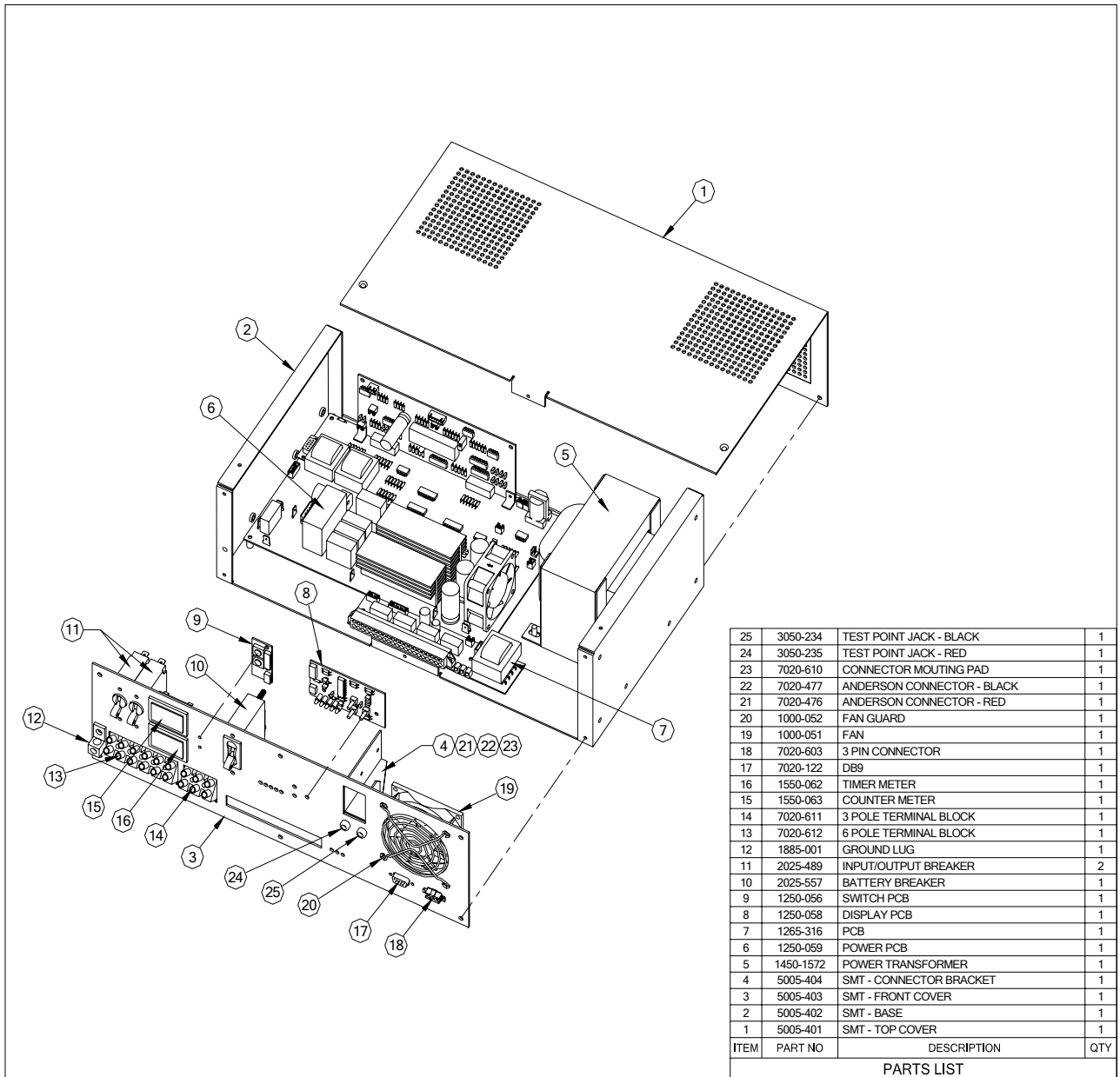

FIGURE 6

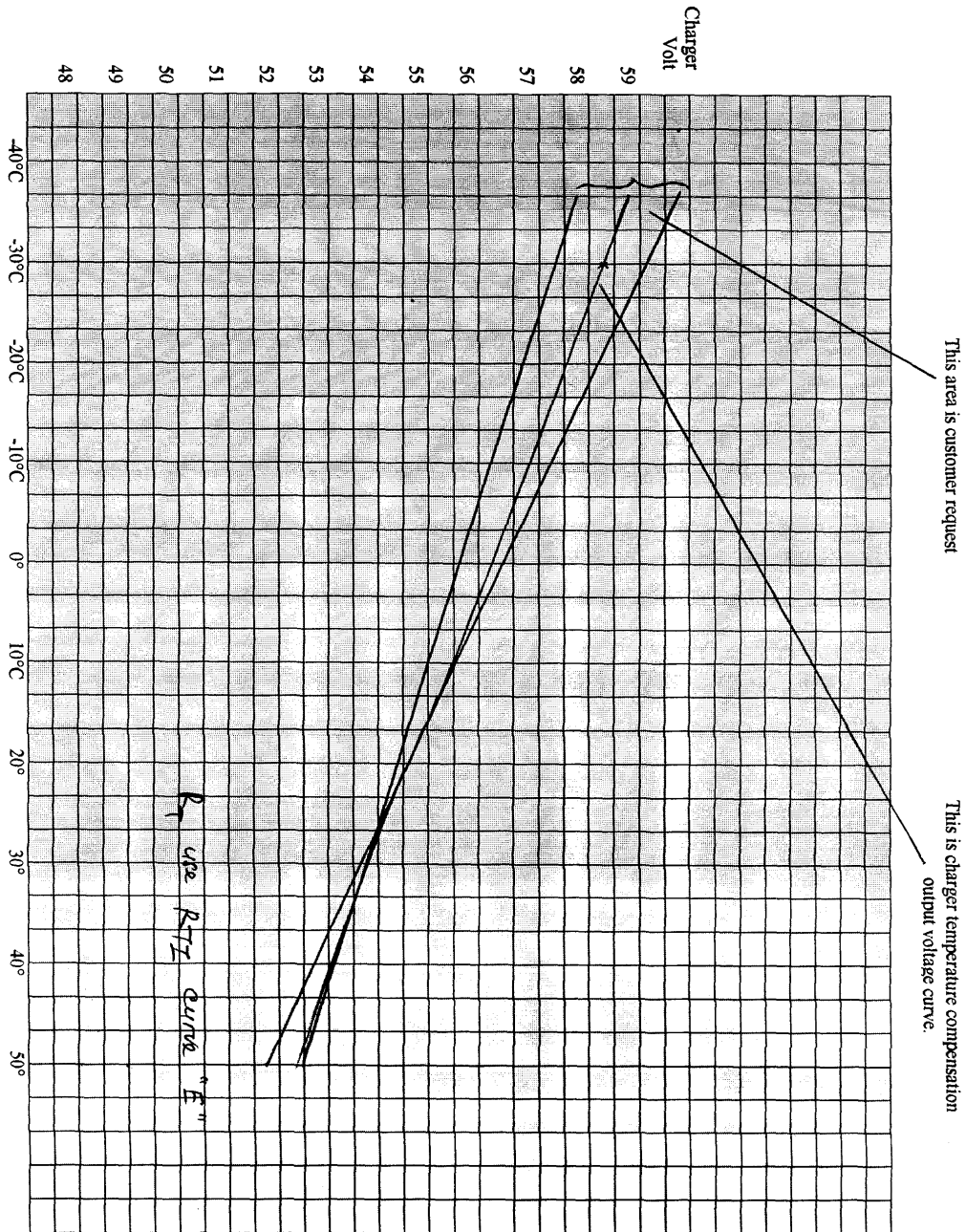

Figure 2 : BATTERY CHARGER CHARACTERISTICS

FIGURE 7  
BATTERY CONNECTION DIAGRAM

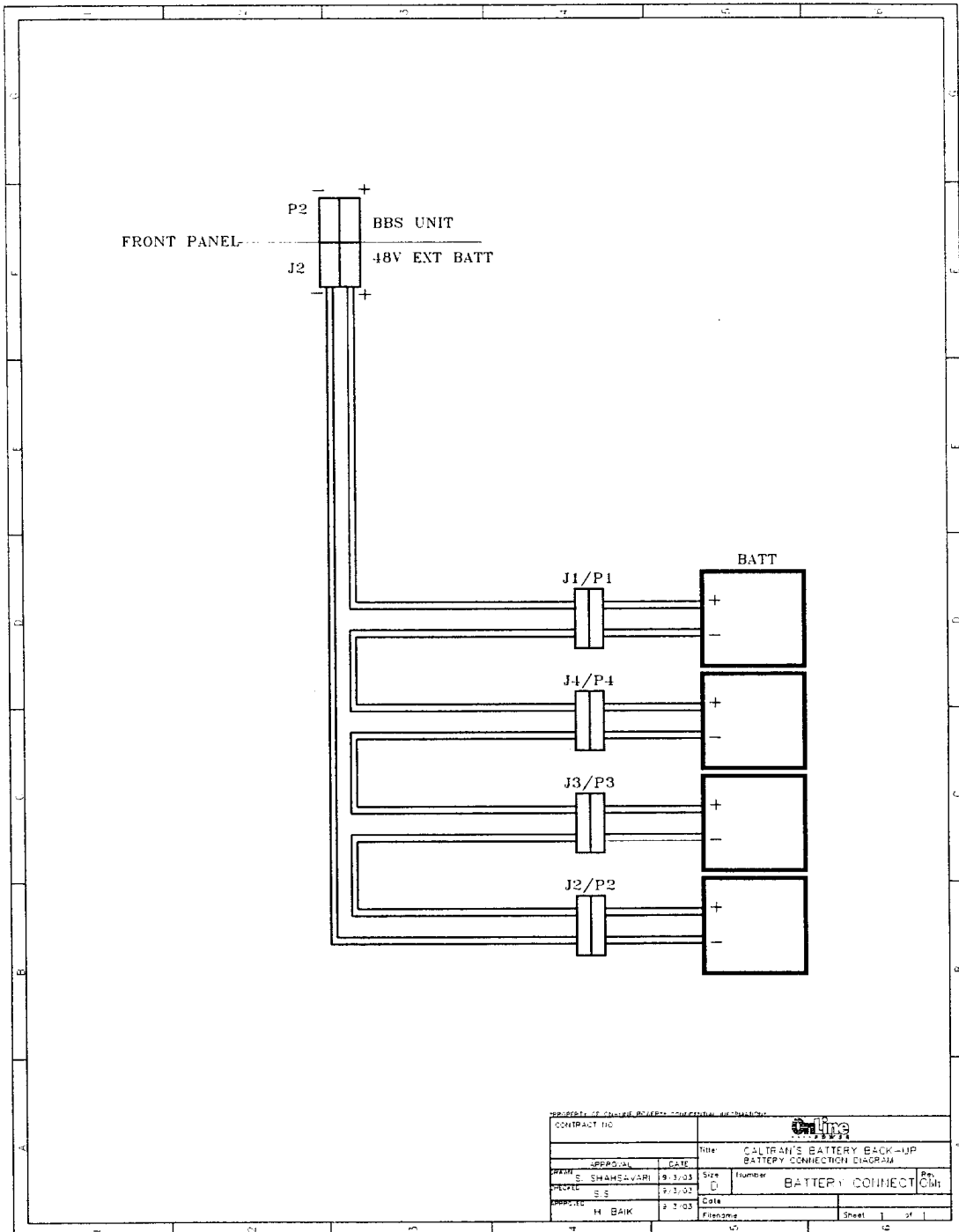

FIGURE 8

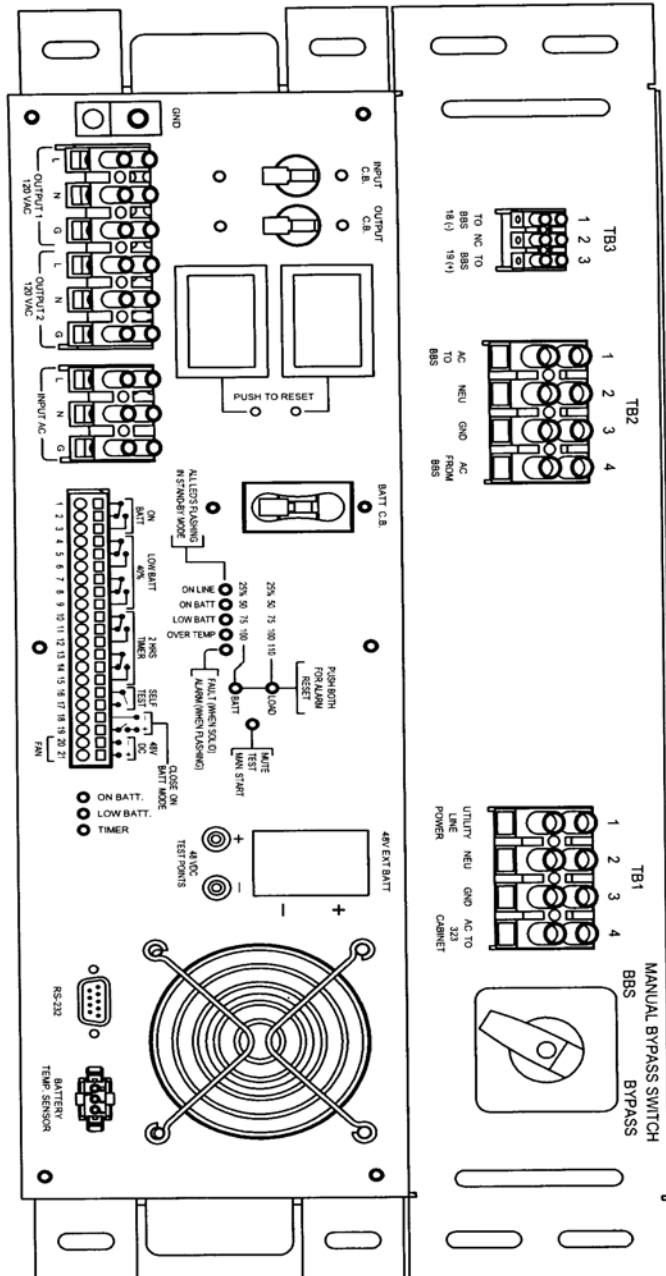
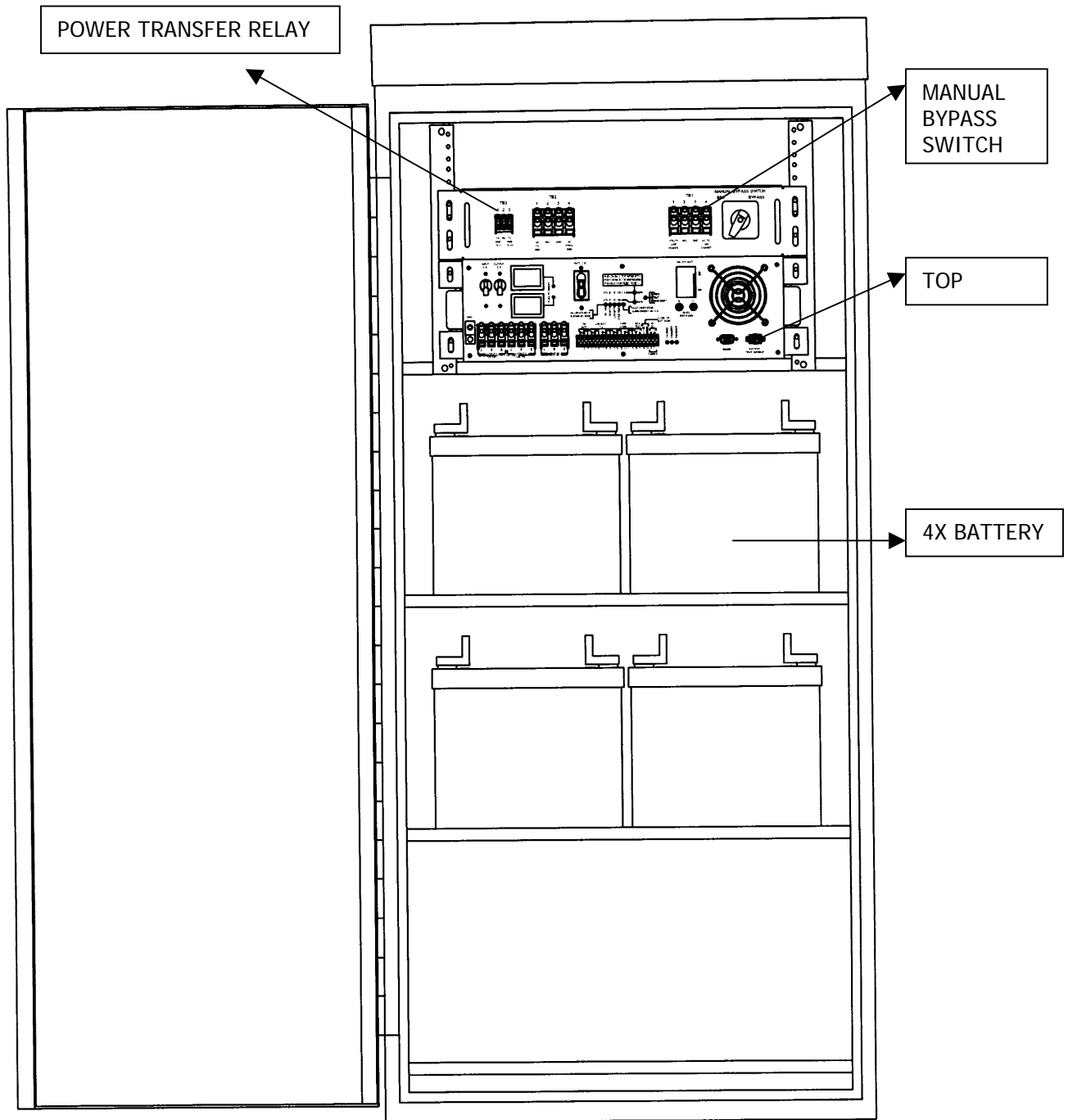

FIGURE 9



TOP CHOICE EXTERNAL CABINET WITH BATTERIES

SCHEMATICS:

- |    |   |           |
|----|---|-----------|
| 1. | CONTROL BOARD:  | 6120-806  |
| 2. | POWER BOARD:  | 6120-807  |
| 3. | SIGNAL RELAY AND AC START:                                      | 6120-808  |
| 4. | SYSTEM SCHEMATIC:   | 6120-763  |
| 5. | TOP CHOICE / MANUAL BYPASS/ PWR TRANSFER RELAY INTERCONNECTION: | 6120-777  |
| 6. | BATT. BACK-UP WITH MBS SYSTEM CUSTOMER INTERCONNECTION          | 6002-1724 |