

# DOUBLE CONVERSION

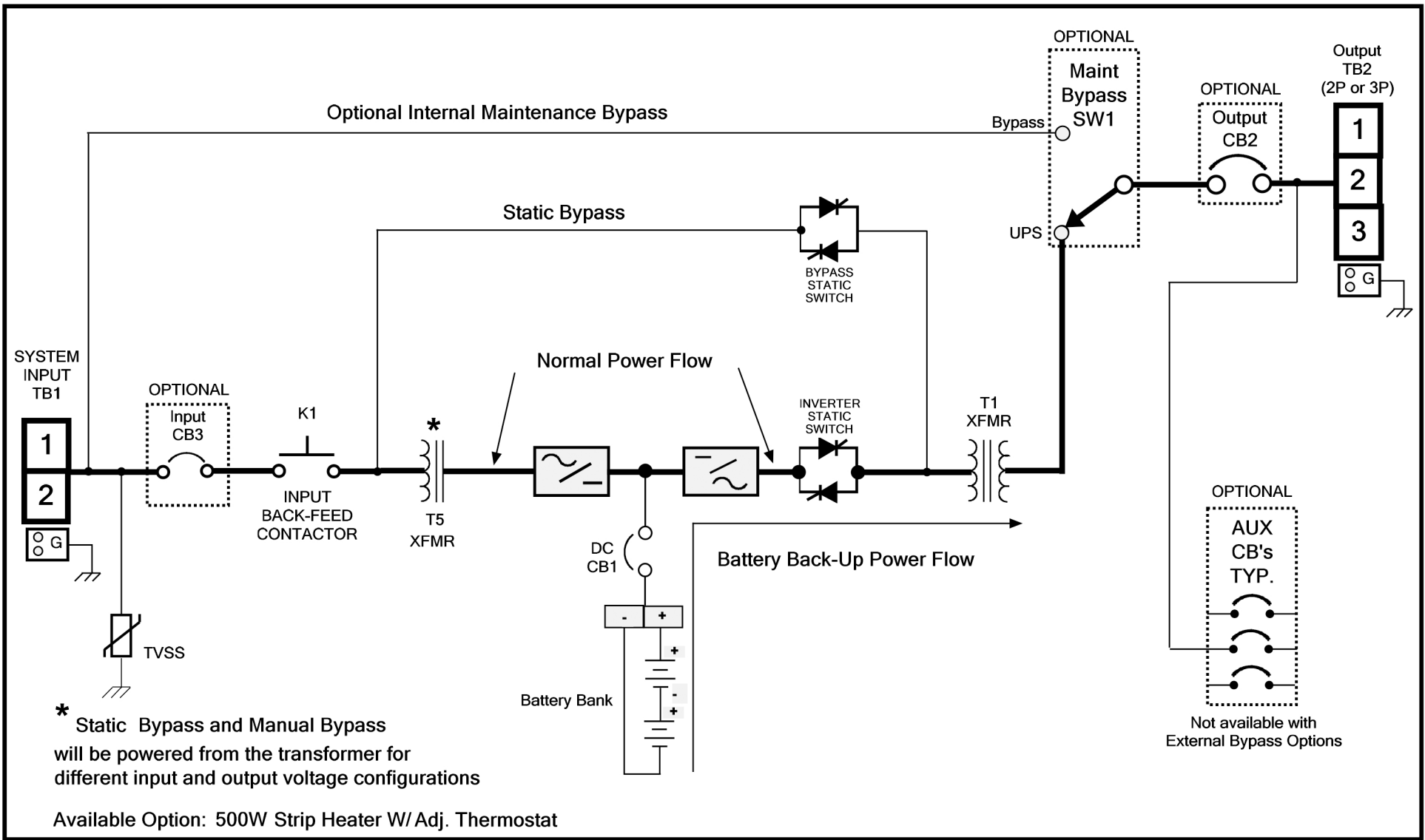

\* Static Bypass and Manual Bypass will be powered from the transformer for different input and output voltage configurations

Available Option: 500W Strip Heater W/Adj. Thermostat

**CRUCIAL POWER PRODUCTS**

TYPICAL: 1-PH LIGHTING INVERTER (DOUBLE CONVERSION) BLOCK DIAGRAM

DRAWN (SDR): S.S	1/2/19	411-TD-003A	REV A
APPVD: RV	1/2/19		

# FAST TRANSFER

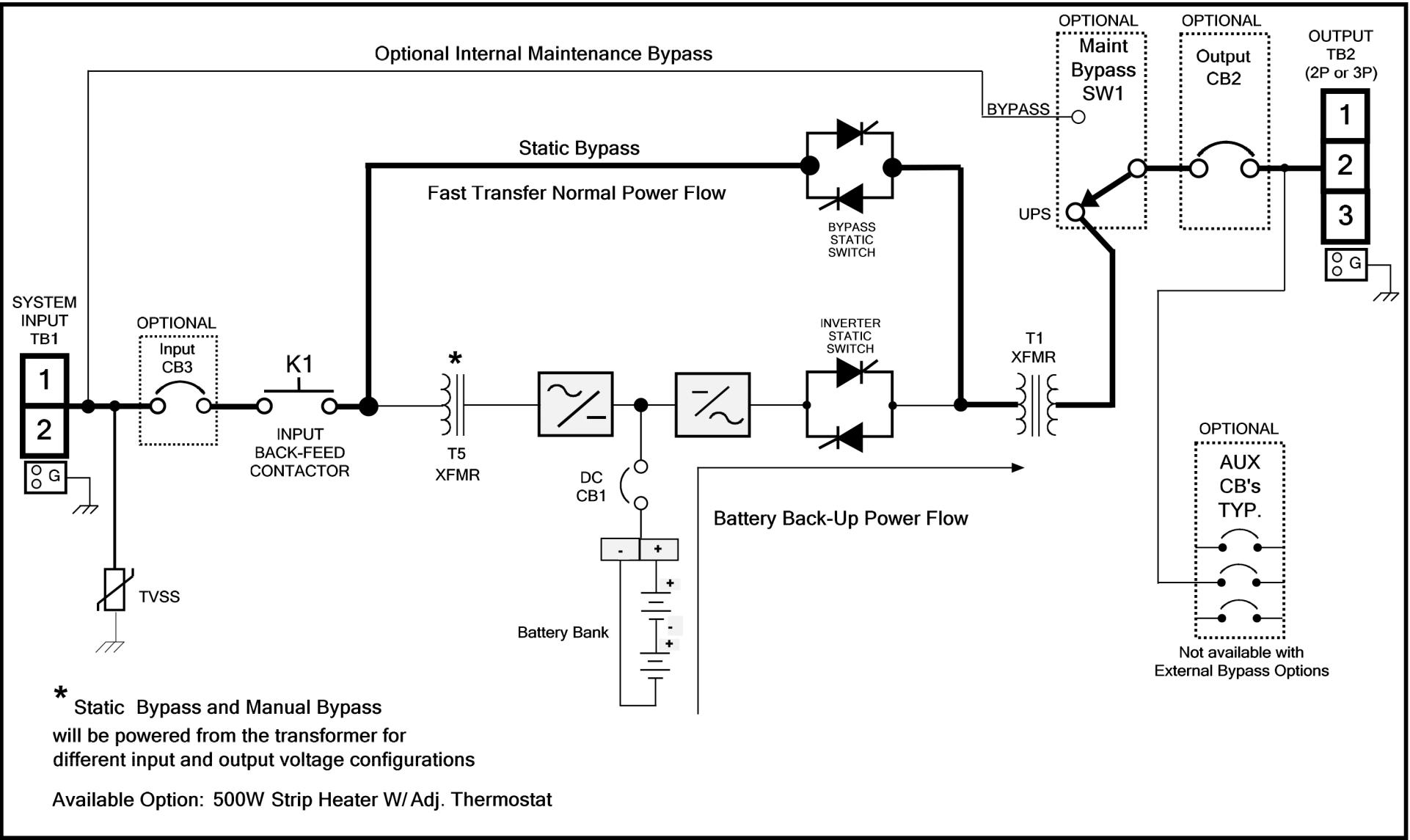

**CRUCIAL POWER PRODUCTS**

TYPICAL: 1-PH LIGHTING INVERTER (FAST TRANSFER) BLOCK DIAGRAM

DRAWN (SDR): S.S	1/2/19	411-TD-003B	REV A
APPVD: RV	1/2/19		

# OUTDOOR INVERTER WITH 90 MIN BACKUP

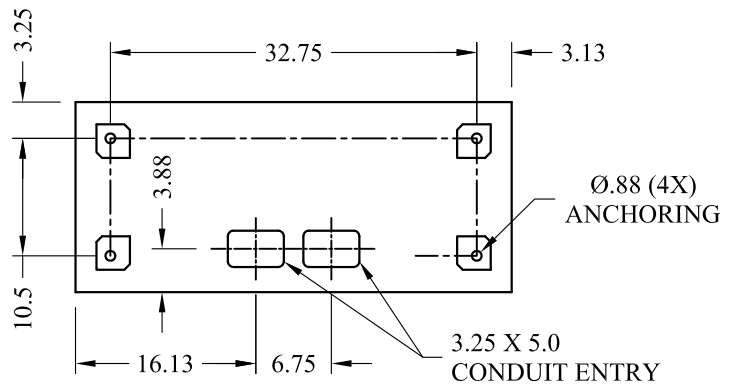

VIEW A-A

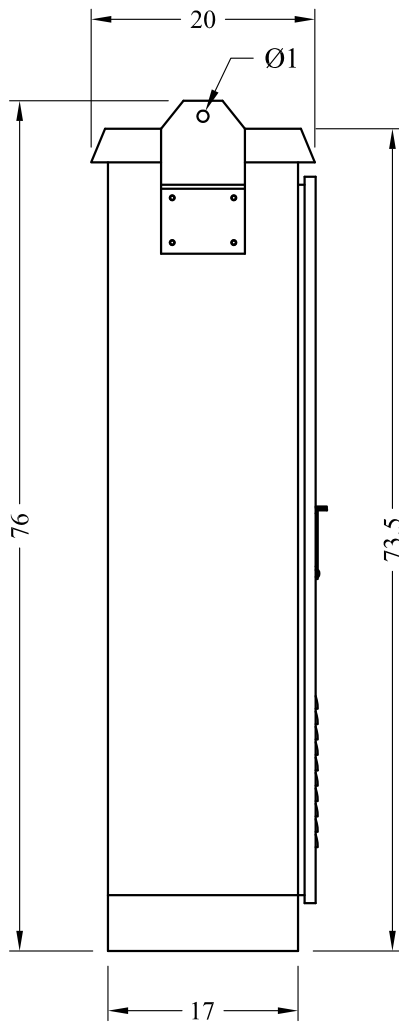

SIDE VIEW

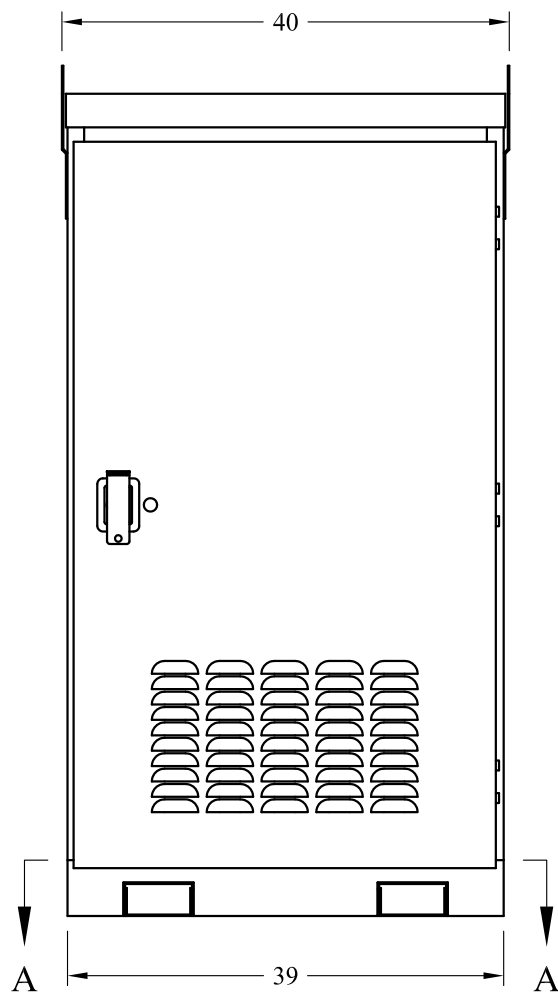

FRONT VIEW

## STD VRLA BATTERY

CRUCIAL POWER PRODUCTS			
WAVE RIDER 1 2.1 KW THRU 5 KW			
DRAWN:	SHERRI	5/18/18	425-TD-A
APPVD:	HENRY	5/18/18	
			REV A

# OUTDOOR INVERTER WITH 90 MIN BACKUP

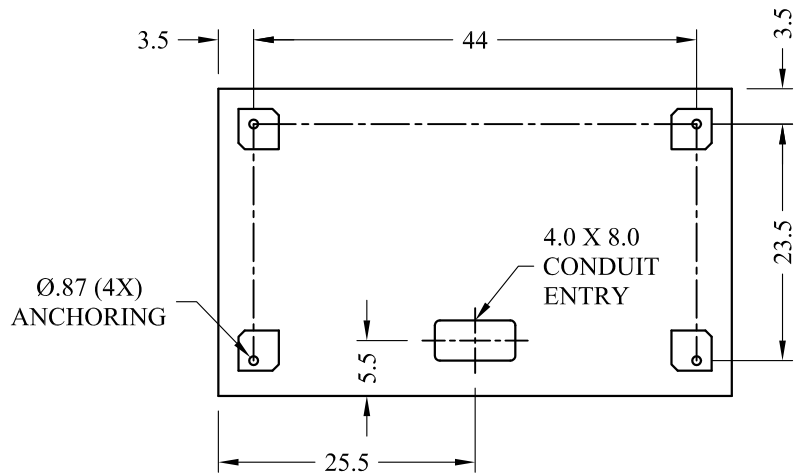

VIEW A-A

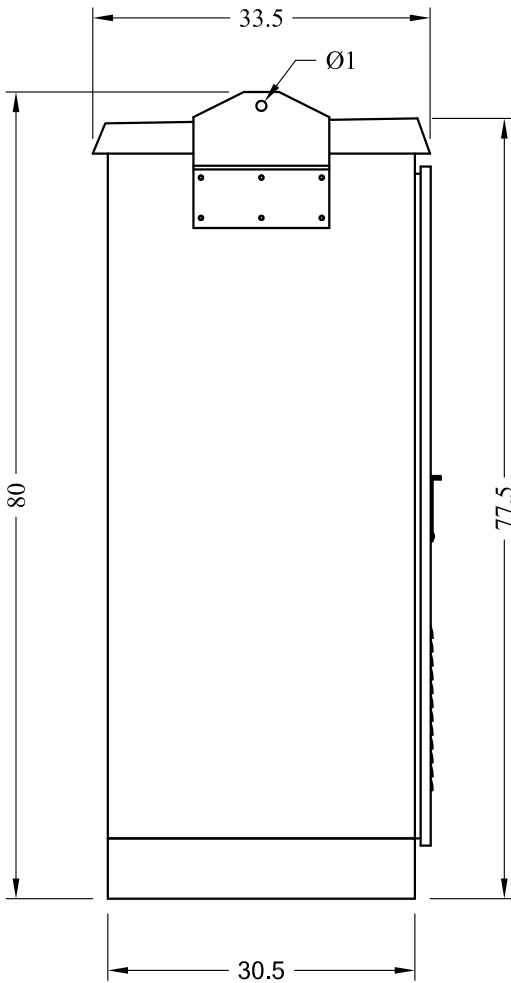

SIDE VIEW

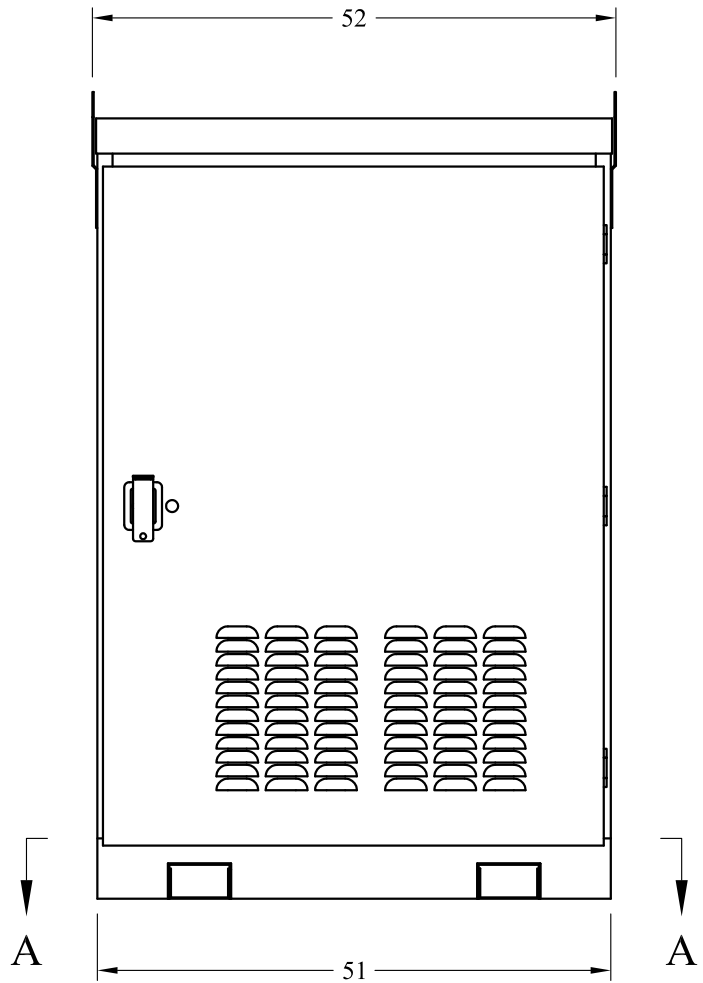

FRONT VIEW

STD VRLA BATTERY

CRUCIAL POWER PRODUCTS			
WAVE RIDER 1			
5.25 KW THRU 17 KW			
DRAWN:	SHERRI	5/18/18	425-TD-B
APPVD:	HENRY	5/18/18	
			REV A

# OUTDOOR INVERTER WITH 90 MIN BACKUP

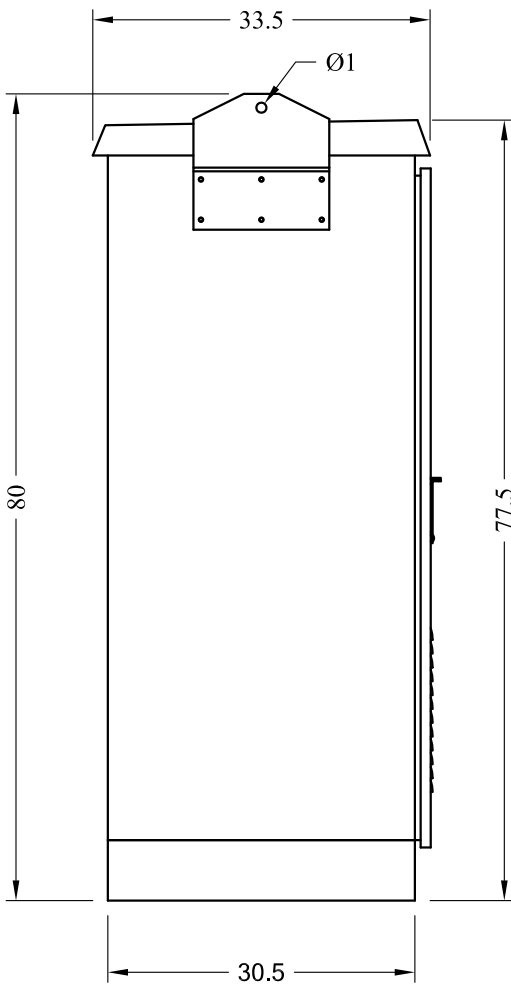
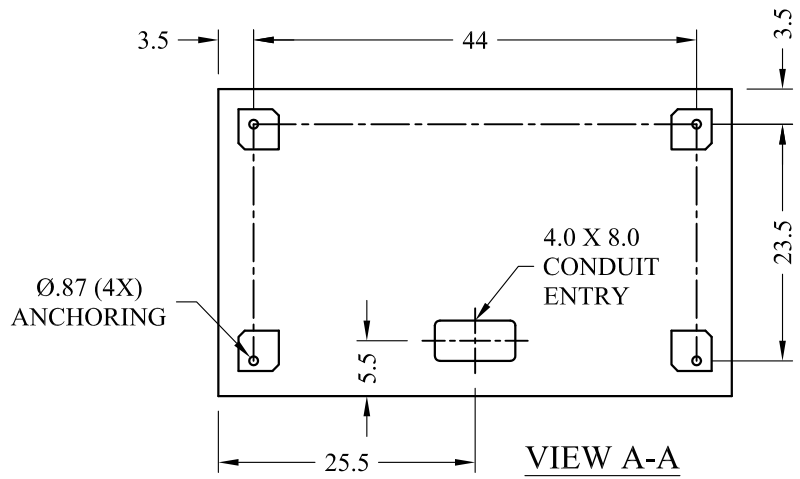

SIDE VIEW

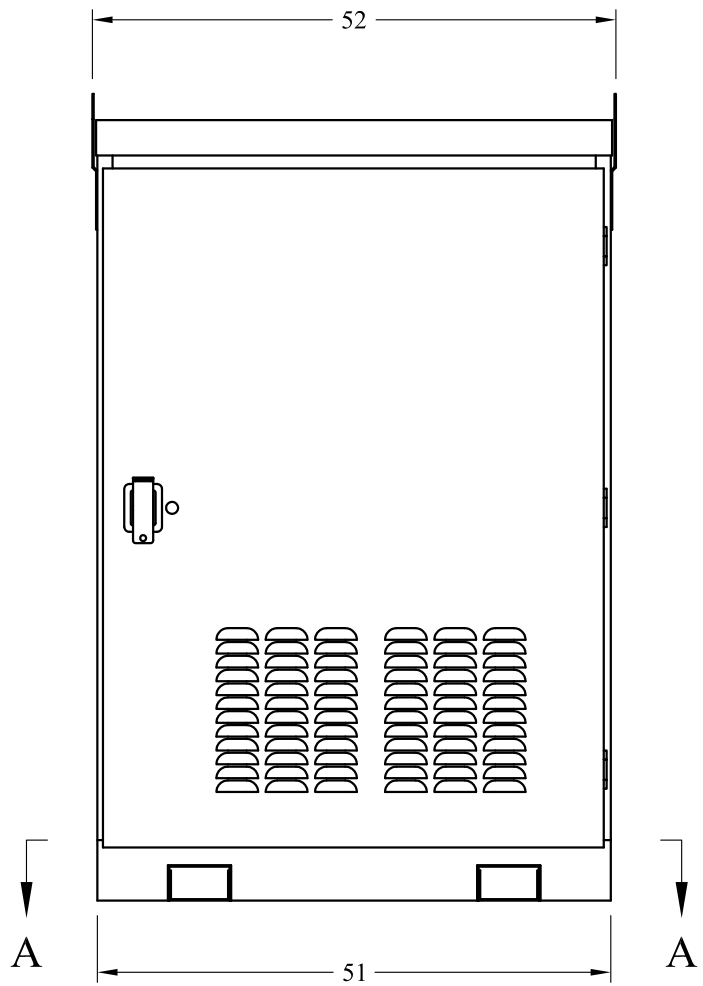

FRONT VIEW

## OPTIONAL LONG LIFE BATTERY

NOTES:  
1) 14KW THRU 17KW HAS 2 CABINETS,  
INVERTER CABINET & BATTERY CABINET.

CRUCIAL POWER PRODUCTS			
WAVE RIDER 1 2.1 KW THRU 17 KW			
DRAWN:	SHERRI	5/18/18	425-TD-C
APPVD:	HENRY	5/18/18	
			REV A