

**Single-Phase
Emergency Lighting Inverter
Installation and Operation Manual**

**Lite Wave Wall Mountable
(200-490W)
Indoor Lighting Inverter**



Document No.: 400-MAN, Rev. B
Contact Numbers: Phone: 800-244-4069

Due to continuous product improvement, this document is subject to change without prior notice
All trademarks and registered trademarks are the property of their respective owners.

Notice of Rights

This document contains proprietary and confidential information of Crucial Power Products. No part of this manual may be reproduced, copied, translated or transmitted, in any form or by any means, without the prior written permission of the manufacturer.

In consideration of the receipt of this document, the recipient agrees not to copy any of its contents, nor to disclose them to or allow them to be used by any person not currently company employee or an employee of the recipient having a need to know, without the express written consent of the company, and further agrees to surrender this document to company when the reason for its receipt has terminated.

Notice of Liability

Information provided in this manual is intended to be accurate and reliable. However, manufacturer assumes no responsibility for its use, nor for any infringement of rights of third parties which may result from its use. THIS DOCUMENT IS PROVIDED "AS IS" AND ANY EXPRESS OR IMPLIED WARRANTIES, INCLUDING, BUT NOT LIMITED TO, THE IMPLIED WARRANTIES OF MERCHANTABILITY AND FITNESS FOR A PARTICULAR PURPOSE ARE DISCLAIMED. IN NO EVENT SHALL ABOVE COMPANY BE LIABLE FOR ANY DIRECT, INDIRECT, INCIDENTAL, SPECIAL, EXEMPLARY, OR CONSEQUENTIAL DAMAGES (INCLUDING, BUT NOT LIMITED TO, PROCUREMENT OF SUBSTITUTE GOODS OR SERVICES; LOSS OF USE, DATA, OR PROFITS; OR BUSINESS INTERRUPTION) HOWEVER CAUSED AND ON ANY THEORY OF LIABILITY, WHETHER IN CONTRACT, STRICT LIABILITY, OR TORT (INCLUDING NEGLIGENCE OR OTHERWISE) ARISING IN ANY WAY OUT OF THE USE OF THIS DOCUMENT, EVEN IF ADVISED OF THE POSSIBILITY OF SUCH DAMAGE.

Trademarks

All trademarks and registered trademarks are the property of their respective owners.

Emergency Lighting Inverter Installation and Operation Manual

Document No.: 400-MAN, Rev. B

January 18, 2024

Table of Contents

Table of Contents	2
Introduction	3
Warranty Registration and Warranty Certificate Request	3
Scope and Audience	3
Safety and Warnings	3
Accessing Product Documentation	4
Service.....	4
Chapter 1. Overview	5
1.1 Product Description	6
1.2 Product Main Features	8
Chapter 2. Safety	11
Chapter 3. Hardware Overview	15
3.1 Key Components.....	16
Chapter 4. Installation	18
4.1 Delivery Space Requirements.....	19
4.2 Site Considerations	20
Chapter 5. Operation	27
5.1 Starting the Unit.....	28
5.2 Turning ON the Unit	29
Chapter 6. Troubleshooting	35
Appendix A – Options	38
Appendix B – Specifications	41

Introduction

Congratulations on selecting one of the fine products from Crucial Power Products, the leader in power protection technology. Our wide product offering includes UPS (Uninterruptible Power Systems), power conditioners, automatic voltage regulators and specialty transformers (e.g., computer-grade, medical-grade). Since our founding in 1972, Crucial Power Products has shipped many of these fine products to discerning customers around the world for use on sensitive equipment and in critical applications.

Warranty Registration and Warranty Certificate Request







Visit our web site at: www.800pwrsrv.com under download tab.

Scope and Audience

This guide is intended to be used as a reference for users responsible for installing, operating, and maintaining this equipment.

Safety and Warnings

This guide uses the following symbols to draw your attention to certain information.

Symbol	Meaning	Description
	Note	Notes emphasize or supplement important points of the main text.
	Tip	Tips provide helpful information, guidelines, or suggestions for performing tasks more effectively.
	Caution	Cautions indicate that failure to take a specified action could result in damage to the hardware.
	DANGER	The Danger symbol warns users of possible injury or death if instructions are not followed.
	Hazardous voltage	Hazardous voltage inside. Only authorized personnel may service this equipment.
	Electrostatic sensitive	Components are Electrostatic Discharge Susceptible (ESDS) Use a grounded ESD wrist strap.

Accessing Product Documentation

The user documentation for the products is available at our website under [downloads tab](#). Please check this site for the most current documentation, including important updates that may have been made after the release of the product.

Service

If you require assistance, please call our 24-hour toll free hot line 800-PWR-SRVC (800-797-7782) or email to info@800pwrsrvc.com. Please have the following information from your unit's nameplate available to speed assistance:

Serial Number:	
KVA/Power Rating:	
Input Voltage:	
Output Voltage:	
Manufacturer Date:	

Chapter 1. Overview

This chapter provides an overview of the Single-Phase Lighting Inverter Standard Series. It includes the system's theory of operation & features.

1.1 Product Description

The Single-Phase Lighting Inverter is manufactured to provide critical power for lighting during a power outage. The Lighting Inverter meets or exceeds the life safety codes of UL924 and UL1778. These codes were established to allow emergency lighting inverters to provide critical power to the lighting circuits during a power failure.

If input power to the inverter is lost during a power outage, the system draws clean sine wave power automatically from its internal battery supply without any interruption. Power is provided for 90 minutes, sufficient time for safe and orderly evacuation from the facility.

An optional Input or output or both transformer(s) allows a 277V input or output voltage unit. The internal valve regulated lead-acid (VRLA) maintenance-free batteries provide 90 minutes of backup power. When input power is restored, the Lighting Inverter resumes normal operation automatically and begins recharging the batteries immediately.

An optional internal bypass circuit maintains power to the load in case an internal unit failure occurs. Comprehensive monitoring capabilities include a Liquid Crystal Display (LCD) panel and five dry relay contacts for remote monitoring.

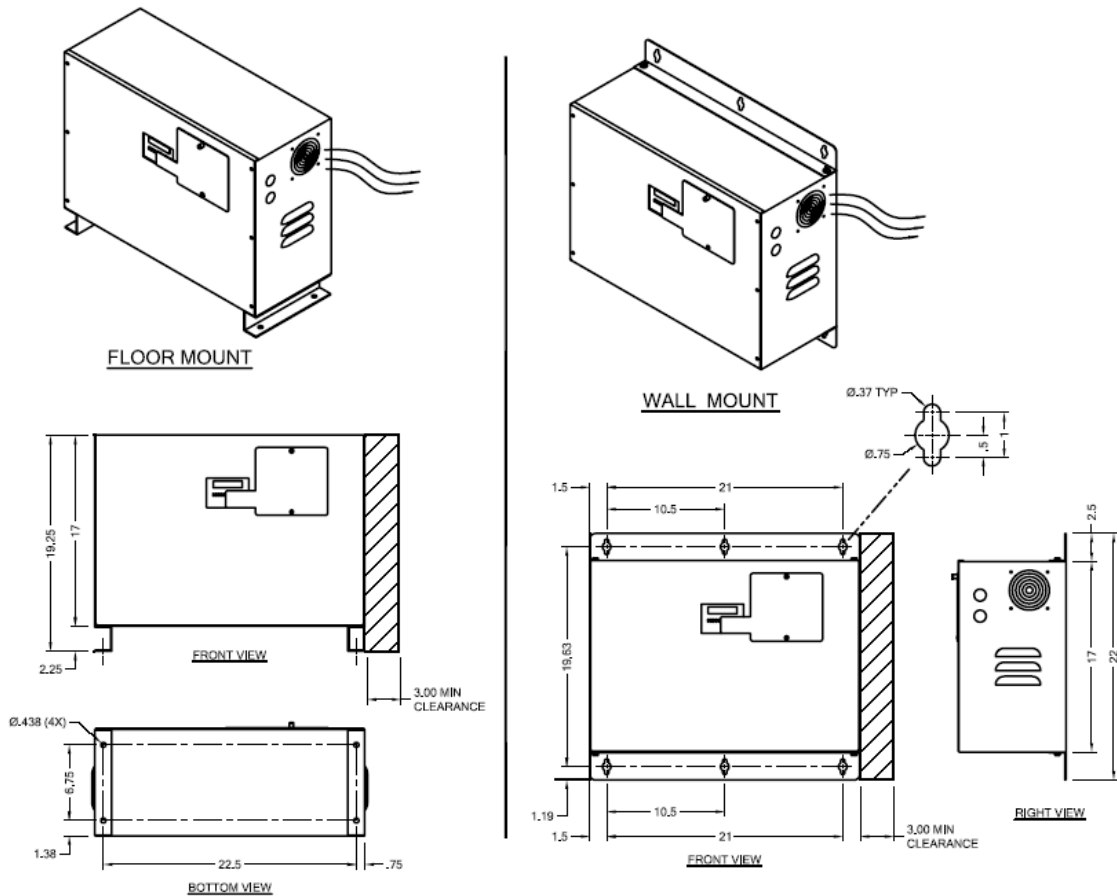

Table 1-1.
Lite Wave

Cabinet

Note: Customer to supply hardware and to ensure the wall structure and material is proper for the load handling of the unit

Overview

**Table 1-2. Model Numbers, Wall/Floor Mountable Lighting Inverter
90 minute battery backup (Batt. 24 VDC)**

Watts	Model Numbers	Input/Output	BTU/HR*	Cabinet Dimension (W"xH"xD")
200W	WM.20A01CP	120V/120V	216	24 X 17 X 9.5
	WM.20R01CP	277V/120V	233	
	WM.20R25CP	277V/277V	233	
	WM.20A25CP	120V/277V	233	
300W	WM.30A01CP	120V/120V	305	“
	WM.30R01CP	277V/120V	353	
	WM.30R25CP	277V/277V	353	
	WM.30A25CP	120V/277V	353	
490W	WM.49A01CP	120V/120V	499	“
	WM.49R01CP	277V/120V	543	
	WM.49R25CP	277V/277V	543	
	WM.49A25CP	120V/277V	543	
(NOTE) * BTU/HR ARE APROX. NUMBER WITH TOLERANCE ± 15% FOR ALL MODELS				

1.2 Product Main Features

The Single-Phase double conversion on-line Emergency Lighting Inverter uninterruptable, clean, Single-Phase power to your critical systems while keeping batteries continuously charged and provide a back-up in the event of a utility power failure.

If a power failure lasts longer than the rated UPS backup time, your UPS will shut down systematically, avoiding battery discharge. As soon as utility power is restored, the UPS will automatically switch to utility power and start recharging the batteries.

As shown in the Single Line diagram, Figure 1-1

- An input filter reduces transients on the mains
- To maintain full battery charge, AC-power is rectified and regulated in the rectifier feeding power to the inverter and battery converter.
- DC power is converted to AC in the inverter passing it on to the load.
- Power is maintained from the battery during power failure. The converter increases voltage to the inverter.

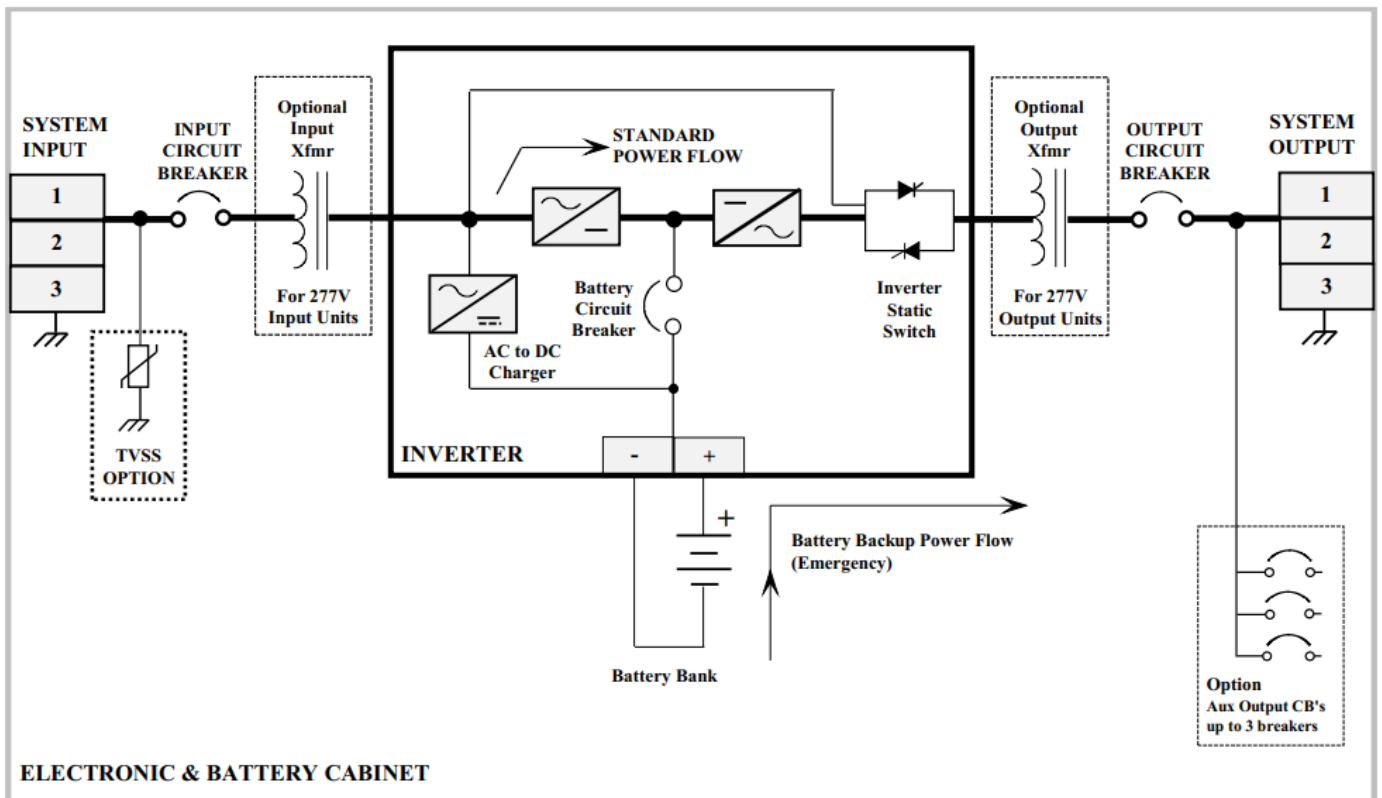

Figure 1-1. Lite Wave Single line Diagram (typical)

1.2.1 Efficiency Optimizer function

The Efficiency Optimizer function is a new feature for the UPS adding cost effectiveness, minimizing power loss and reducing power consumption. Alternating between bypass and on-line modes is achieved automatically and in accordance with the conditions of the utility power. On-line mode may be used during times of intermittent power supply, and bypass mode when power flows smoothly in order to obtain greatest efficiency. Irregularities can be detected in less than a second, and on-line mode reactivated immediately. Switching back to online mode occurs when input voltage is outside $\pm 10\%$ or nominal ($\pm 15\%$ selectable), when input frequency is outside of $\pm 3\text{Hz}$ or when no input line is available.

Although high efficiency is standard, the default operation is in on-line mode. Bypass can be activated in the LCD panel; though on-line can be run permanently if preferred.

1.2.2 Free Run Mode

The UPS operates in free run mode when input frequency is outside of the selected input frequency range. Free run mode is when output frequency does not match input frequency. When starting the UPS, the frequency regulation detected is 50 or 60 Hz $\pm 0.25\text{Hz}$. Please refer to chapter 7.2 if you want bypass available while running in free run mode.

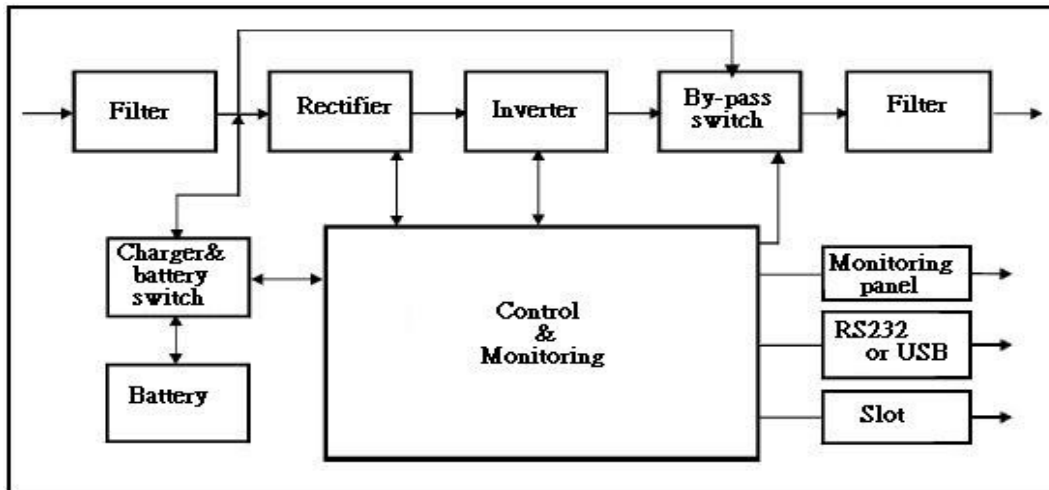

1.2.3 Diagnostic tests

When you start the UPS, a diagnostic test is automatically executed that checks electronics, battery, and reports any problems on the LCD display.

An advanced battery management system always monitors the conditions of the batteries sends any forewarnings if replacement is needed. Otherwise every 30 days of normal mode operation, a battery discharge test is performed and any problems reported on the LCD display.

Except during the first 24 hours after startup while the UPS is in charging mode (please see chapter 7.2), diagnostic tests can be performed manually from the front panel at any time.

1.2.4 Bypass Enable:

Under the Following Conditions, the bypass will be enabled:

1. Overload
2. Inverter failure
3. Over temperature
4. DC bus failure

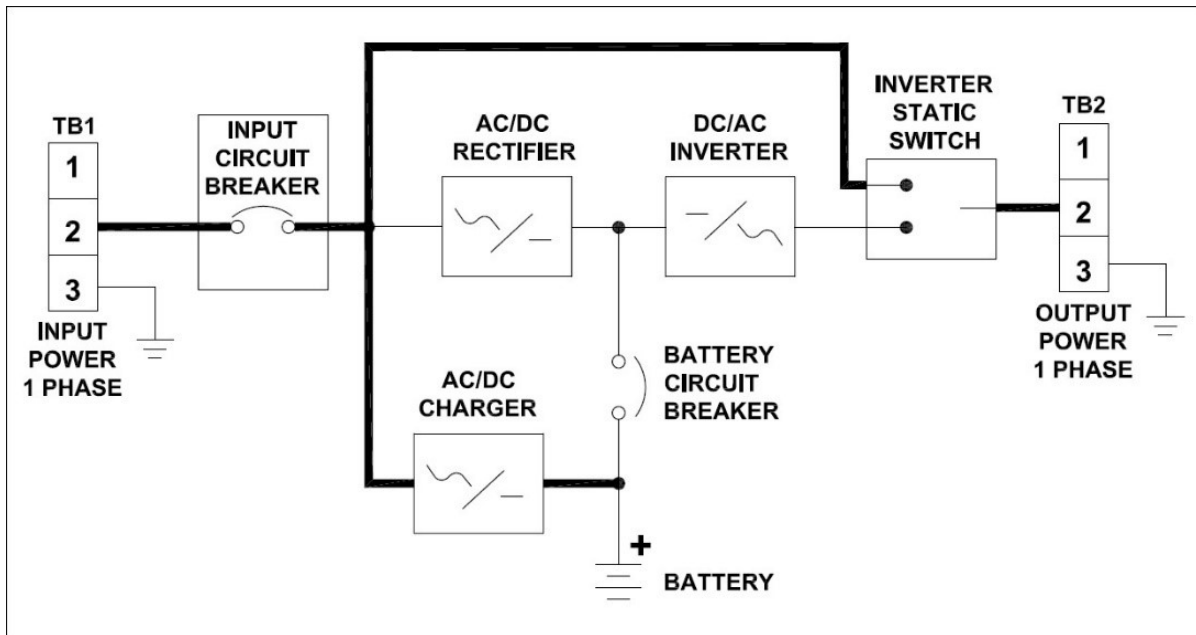

Chapter 2. Safety

This chapter contains safety precautions to observe when operating or servicing electrical equipment. The symbols shown are used extensively throughout this manual. Always heed these precautions because they are essential to the safe operation and servicing of this product.

Safety



DANGER: This Equipment is intended to be permanently connected. Only factory-trained or authorized personnel should attempt to install or repair the unit or its battery system. Improper installation has proven to be the single most significant cause of start-up problems. High AC and DC electrical voltages are present throughout the unit(s) and incorrect installation, or servicing could result in electrocution, fire, explosion, or equipment failure.



DANGER: Read this manual in its entirety before performing the installation, start-up, operation, or maintenance of the UPS unit or battery systems. Failure to do so could result in electrocution, fire, explosion, or equipment failure.



DANGER: All power connections must be completed by a licensed electrician who is experienced in wiring this type of equipment. Wiring must be installed in accordance with all applicable national and local electrical codes. Improper wiring may cause damage to the equipment, injury or death of personnel. Verify that all high and low voltage input power circuits are de-energized and locked out before installing cables or making any electrical connections.



DANGER: Exercise extreme care when handling unit and batteries to avoid equipment damage or injury to personnel. Cabinets weigh several hundred pounds.



DANGER: Test lift and balance the cabinets before moving. Maintain minimum tilt from vertical at all times. The bottom structure will support the unit only if the forklift forks are completely underneath the unit.



DANGER: Observe all battery safety precautions during installation or service of the unit or batteries. Even with the battery circuit breaker in the off position, the danger of electrocution may still be present. The battery power to the unit must be locked and tagged “off” before performing any service or work on the unit. The battery manufacturer’s safety information and material safety data sheet are located in a pocket attached to inside the front door of each unit. Failure to follow those instructions and the instruction listed above and elsewhere in this manual could result in an explosion, fire, equipment failure, or electrocution.

Safety



DANGER: All power to the unit must be locked and tagged "off" before performing any service or work on the unit. Failure to do so could result in electrocution.



DANGER: In case of fire involving electrical equipment, only carbon dioxide fire extinguishers, or those approved for use on electrical equipment, should be used. Use of water on fires involving live high voltage electrical circuits could present an electrocution hazard.



DANGER: Extreme caution is required when performing maintenance. Lethal voltages exist within the equipment during operation. Observe all warnings and cautions in this manual. Failure to comply may result in serious injury or death. Obtain qualified service for this equipment as instructed.



DANGER: Be constantly aware that the unit system contains high DC as well as AC voltages. With input power off and the battery disconnected, high voltage at the filter capacitors and power circuits should discharge within 30 seconds. However, power circuit failures can occur, so you should always assume that high voltage might still exist after shutdown. Verify that power is off using AC and DC voltmeters before making contact.



DANGER: Some components within the cabinets are not connected to chassis ground. Any contact between floating circuits and the chassis is a lethal shock hazard.



DANGER: Internal battery strapping must be verified by the customer prior to moving this unit.

This unit contains non-spillable batteries. Keep the unit upright. Do not stack. Do not tip. Always follow the battery manufacturer's safety information, located in a pocket attached to the inside of the door of your unit, to prevent an accident that could result in injury or death.

Safety



DANGER: Lead-acid batteries contain hazardous materials. Batteries must be handled, transported, and recycled or discarded in accordance with federal, state, and local regulations. Because lead is a toxic substance, lead-acid batteries should be recycled rather than discarded.

Do not dispose of batteries in a fire, the batteries may explode.

Do not open or mutilate the batteries. Released electrolytes are harmful to the skin and eyes and may be toxic.

A battery can have a high short circuit current and present a risk of electrical shock. The following precautions should be observed when working on batteries:

- 1. Remove watches, rings, or other metal objects.**
- 2. Use tools with insulated handles.**
- 3. Wear rubber gloves and boots.**
- 4. Do not lay tools or metal parts on top of batteries.**
- 5. Disconnect charging source prior to connecting or disconnecting battery terminals.**
- 6. Determine whether battery is inadvertently grounded. if so, remove the source of the ground. Contact with any part of a grounded battery can result in electrical shock. The likelihood of such shock will be reduced if such grounds are removed during installation and maintenance.**
- 7. Lead-acid batteries can present a risk of fire because they generate hydrogen gas. The following procedures should be followed:**
 - Do not smoke when near batteries.
 - Do not cause flame or spark in battery area.
- 8. Discharge static electricity from your body before touching batteries by first touching a grounded surface.**

Chapter 3. Hardware Overview

This chapter provides an overview of the system hardware.

3.1 Key Components

Figure 3-1 shows the key system components and describes them.

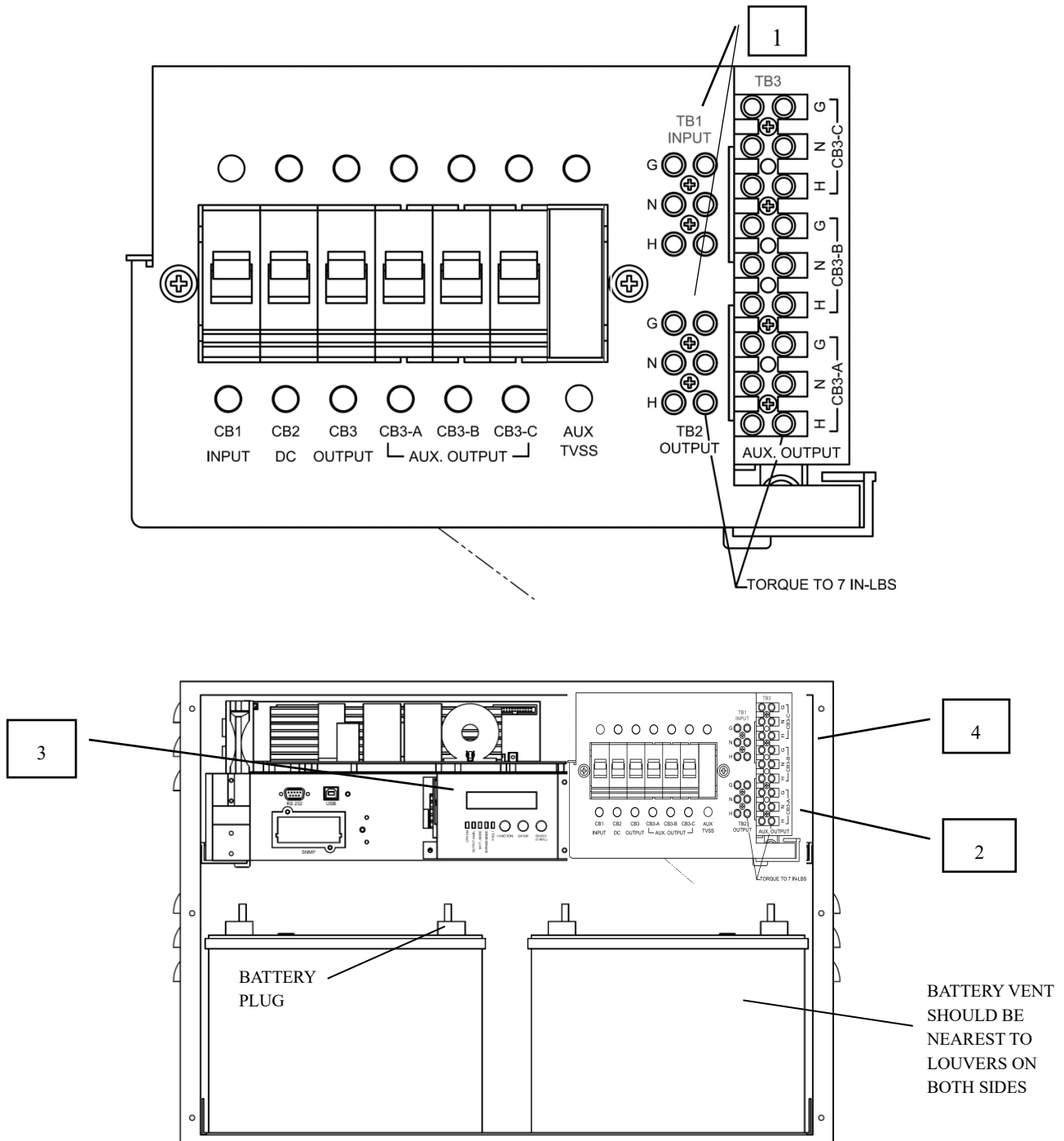

Figure 3-1. Lite Wave Key Components

Hardware Overview

Table 3-1. Key Components description

Callout	Components	Function
1	Input / Output / DC Connection	Conveniently located close to knock outs terminal blocks for Input, Output and Battery connection.
2	Optional Aux. Output Breaker(s) Connection	Auxiliary Norm ON C.B options, 1pole, 10amp (maximum of 3 each).
3	LCD Panel	Refer to Section 5.2 for detail.
4	Fan and Fan grill	This fan works as exhaust air and should not be abstracted by objects for free air flow.
5	Batteries	Each system includes 2 batteries, for a 24VDC power.

Chapter 4. Installation

This chapter describes how to install the system. It includes pre-installation information along with guidelines for storing the system for future use.

4.1 Delivery Space Requirements

The following figures show the dimensions of the system cabinets as well as key components used for cable access and mounting.

Verify that the delivery area, the destination, and the path between them meet the standard delivery clearance and weight requirements of the system.

The delivery area must provide enough space and floor strength to support the packaged equipment cartons for the system. Doorways and hallways must provide enough clearance to move the equipment safely from the delivery area to the destination. Permanent obstructions such as pillars or narrow doorways can cause equipment damage. If necessary, plan for the removal of walls or doors.

Verify that all floors, stairs, and elevators you use when moving the system to its destination can support the weight and size of the equipment. Failure to do so could damage the equipment or your site.

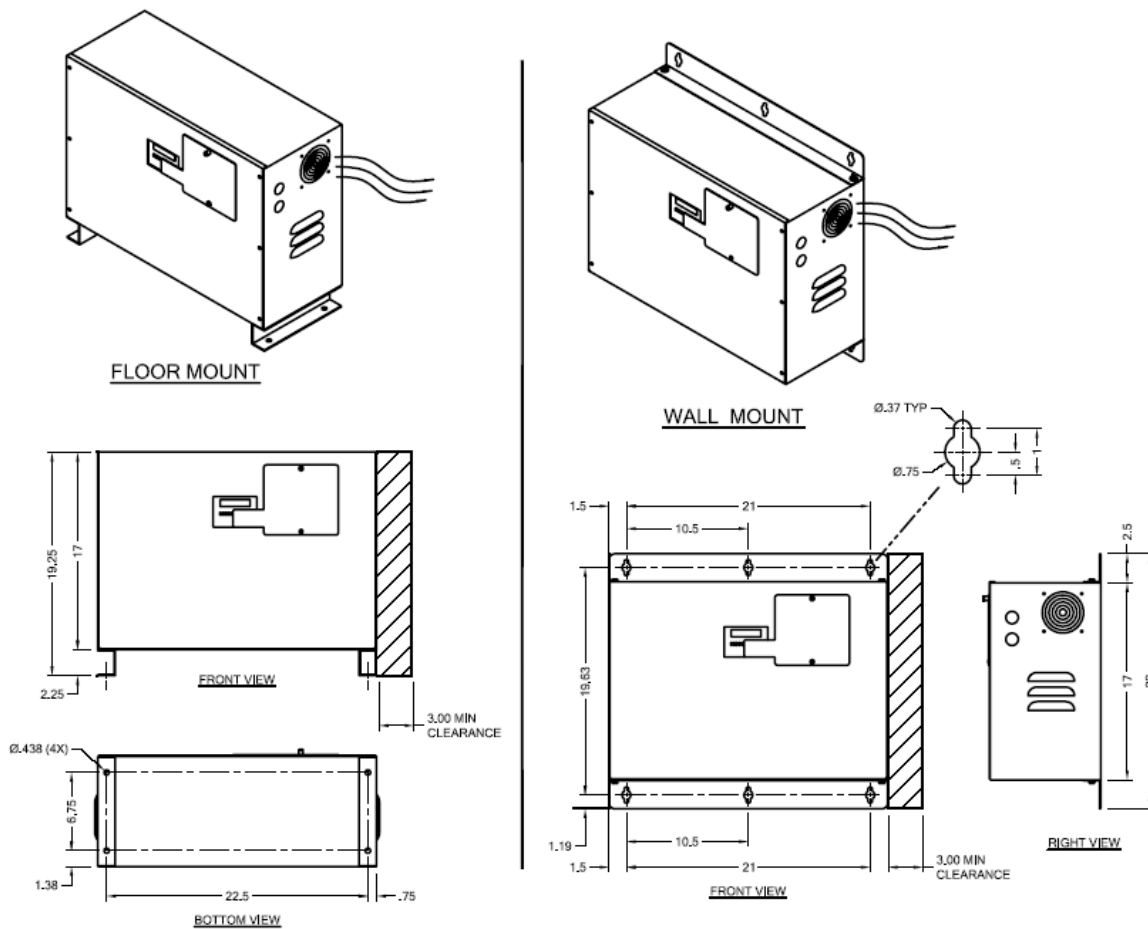

Figure 0-1. Lite Wave Cabinet Access and Mounting



Note: Do not remove any knockouts that will not be used

4.2 Site Considerations

Planning the proper location and layout of the system prior to installing it is essential for successful operation. To ensure normal operation and to avoid unnecessary maintenance, plan your site configuration and prepare your site before installation.

The system is designed for indoor installation and meets NEMA specifications for operating temperature, humidity, and utility voltage. The system enclosures are rugged and corrosion resistant.

All servicing is performed through the front of the unit; therefore, leave sufficient room in the front of the unit for service access.

The following precautions will help you plan an acceptable operating environment for the system:

- **Select a flat location that is clean, with no dust or exposure to direct sunlight or vibrations. The location should provide a sturdy, level surface that can support the system. Avoid locations with inclined floors.**
- **The location should not be prone to variations in temperature and humidity or be close to strong magnetic fields or a device that generates electric noise.**
- **The unit should not place the system next to, on top of, or below any device that generates heat or will block the free flow of air through the system's ventilation slots**
- **The Lighting Inverter cabinets provide cable and conduit openings on the top and sides of the cabinet. Be sure these areas are not blocked and can be easily accessed to expedite installation.**
- **Electrical equipment generates heat. Ambient air temperature might not be adequate to cool equipment to acceptable operating temperatures without adequate circulation. Ensure that the room in which the system will operate has adequate air circulation.**



Caution: Always follow proper ESD-prevention procedures to avoid damage to equipment. Damage from static discharge can cause immediate or intermittent equipment failure.



Caution: For sites with **Generator** and **Automatic Transfer Switch (ATS)** in conjunction with the unit, make sure the ATS has an open transition with minimum 20 milli-seconds transfer time (gap) in **both directions**

4.2.1 Operating Environment

The location you choose for installation should confirm to the following conditions.

Table 0-1. Inverter Environmental Specifications

Inverter Environment	Description
Operating Temperature:	0° to 40°C (32 to 104°F) Battery compartment to be kept at battery operating temperature
Altitude:	1,829 meters (6,000 feet) de-rate 10% for each additional 305 meters (1,000 feet) up to 2,744 meters (9,000 feet)
Relative humidity:	0% to 95% (non-condensing)
Audible Noise:	40 dBA, typical

Table 4-2. Battery Environmental Specifications

Battery Environment	Description
Ambient temperature:	20° to 25°C (68° to 77 °F)
Relative humidity:	0% to 95% (non-condensing)
Operating altitude:	1,829 meters (6,000 feet) de-rate 10% for each additional 305 meters (1,000 feet) up to 2,744 meters (9,000 feet)



Caution: Operating batteries outside of the specifications will shorten battery life significantly.

4.2.2 Floor Load Ratings

The floor space at the installation site must be strong enough to support the combined weight of the Lighting Inverter unit and all its batteries. To ensure adequate load-bearing capacity, plan for the maximum configuration.

4.2.3 Wall Mounting

Customer to supply hardware and to ensure the wall structure and material is proper for the load handling of the unit

4.2.4 Inspecting the Shipment

The equipment included in your shipment consists of one Lighting Inverter cabinet. Batteries will typically ship separately unless specified otherwise. The contents are covered with protective wrapping and packaged in heavy-duty cardboard. Each item is labeled with the component name for easy identification.

When the equipment arrives, count the number of items delivered to ensure that you have the complete shipment. Inspect all protective wrapping or crates and any boxes for signs of rough handling or damage, such as punctures and crushed sides, preferably without moving the equipment. If the shipping container or equipment itself shows evidence of damage, record the damage on the receiving document before signing for receipt of the equipment. Damage claims should be filed directly with the carrier.

Thoroughly inspect each battery for any signs of damage. If there is any damage, reject the shipment and notify the manufacturer by email services@800pwrsrvc.com. If possible, photograph the damage for future reference. As you unpack the pallet or container, check each battery box for damage on all sides, the top and bottom. If there is any sign of damage, photograph the damage if possible, and email services@800pwrsrvc.com.

4.2.5 Offloading the System

Because the system is designed for pad mounting, it is not accompanied by casters. At the user's discretion, a forklift can be used to off load the unit from the shipping pallet. Always be sure that the load capacity of the forklift is sufficient to support the weight of the unit and its batteries.



DANGER: Exercise extreme care when handling the cabinets to avoid equipment damage or injury to personnel. Each cabinet weighs several hundred pounds. Test lift and balance the cabinets before moving. Maintain minimum tilt from vertical at all times. The bottom structure will support the unit only if the forklift forks are completely underneath the unit.

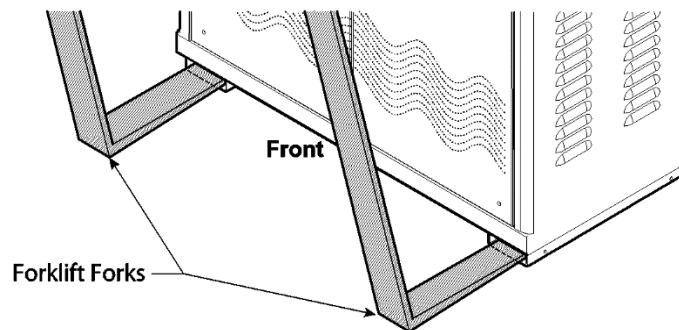

4.2.6 Climatization

Units that are shipped or stored at extreme temperatures require time to adjust to operating temperatures before startup. If the unit arrives in hot or cold weather, do not unpack it until it has been allowed to reach room temperature (one to two hours). Immediately exposing the unit to warm temperature can cause condensation to occur, which could damage the electronics. If you notice any condensation, allow the unit to stand unattended for one to two hours, and then unpack it.

4.2.7 Unpacking the Equipment

After checking the cartons for signs of damage, perform the following steps to unpack the equipment:

1. **Open all cartons.**
2. **Compare the items received to the packing list. If an item is missing or damaged, contact your place of purchase.**
3. **Remove all packing materials, envelopes, and boxes from the cartons. Please keep all packing materials and cartons in case you need to transport or ship the unit.**

In addition to the contents supplied with the unit, the user must supply a forklift to perform the installation.



Note: After unpacking and **before turn-on:**

use plastic cover provided in the pouch on the front door to cover the unit during installation and while waiting for turn on, to prevent dust, construction debris and any other foreign object entering the unit.

Accumulation of dust and debris on all electronic will cause damage which will not be covered by warranty

4.2.8 Cabling and mounting

The top and sides of the unit have conduit openings for running cables.

1. **Before placing the unit onto the mounting bolts where it will be installed, remove the predrilled conduit knockouts on the top and sides of the cabinet**



Note: The predrilled conduit knockouts are positioned to prevent airflow disruptions that could cause the unit to overheat. If site restrictions prevent routing the conduit to the locations of the conduit knockouts, do not drill holes in the cabinet without first consulting the factory via email Service@800pwrsrc.com. Our engineers will assist you in locating the conduit to maintain unit reliability.

4. **Determine which knockouts will be used to route cables into and out of the unit. Remove only the conduit knockouts that are to be used.**
5. **Measure the locations for the conduits on the conduit knockouts.**
6. **Punch holes in the conduit knockouts.**
7. **Anchor the cabinet to the mounting pad at the four mounting locations**
8. **Anchor the conduits to the conduit knockouts.**



Note: Do not remove any knockouts that will not be used

4.2.9 Electrical Connections

The following sections describe how to perform the electrical connections. In these sections, “TB” refers to terminal block. Before making electrical connections, observe the following:



DANGER: Verify that all customer-supplied wiring is de-energized before performing any electrical work. Failure to do so could result in electrocution, injury, or damage to equipment.



DANGER: Even when the unit is off, there are potentially dangerous voltages within the power wave unit due to the batteries. Exercise extreme care when working within the power wave enclosure to avoid the possibility of electrocution, injury or damage to the equipment.

Installation

4.2.9.1 Input/Output/Load Connection

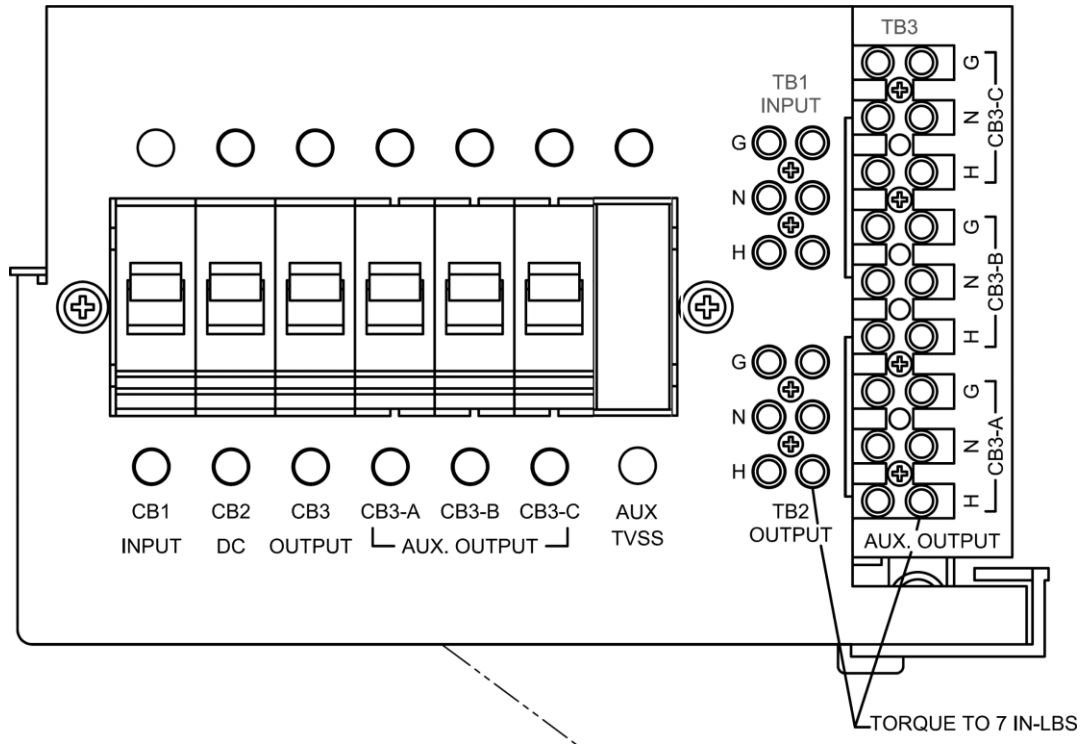

SYTEM RATING (WATTS)	INPUT / OUTPUT/ DC TB
200W – 490W	#22 - #10 AWG

Figure 4-2. Power connection

Table 4-3. Battery Torque Values

SYTEM RATING (WATTS)	(BATTERY TYPE) TORQUE (INCH LBS)	(BATTERY TYPE) TORQUE (INCH LBS)
200W	HPS12-90W-X (55 IN-LBS)	HRL12150WFR (45 IN-LBS)
300W	UNA12-150 (75 IN-LBS)	HRL12150WFR (120 IN-LBS)
490W	UNA12-200 (75 IN-LBS)	HRL12200WFR (45 IN-LBS)

Installation

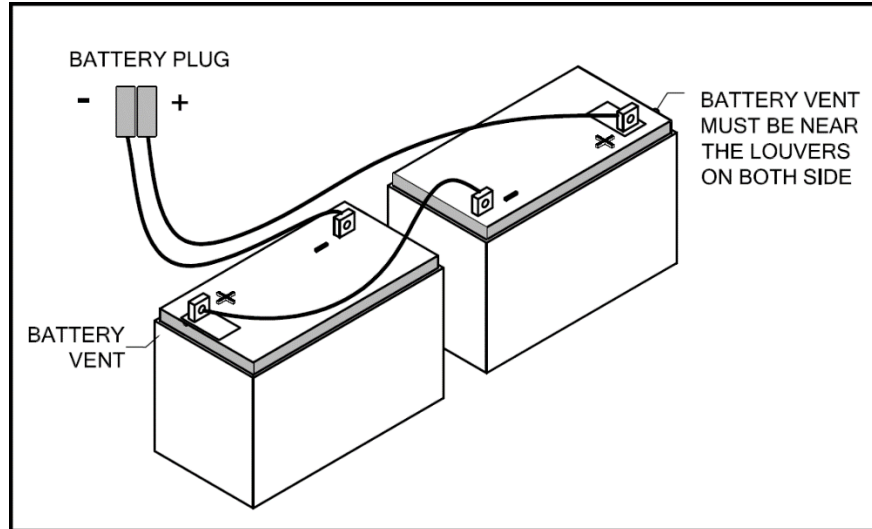

Caution:

Use of any non-Factory Tested/UL924 Certified batteries, including those with similar brand name and part number, will void the systems UL 924 Safety Certification Listing. Please call or e-mail Power Services for tested/certified replacement batteries.

4.2.10 Storing the System

If you will not be using the system as soon as you receive it, keep it in its original packing material and store it in an indoor environment that meets the following conditions.

Specification	Description
Ambient temperature:	-20° to 70°C (-4° to 158°F)
Relative humidity:	0% to 95% (non-condensing)



Note: After unpacking and **before turn-on:**

Use plastic cover provided in the pouch on the front door to cover the unit during installation and while waiting for turn on, to prevent dust, construction debris and any other foreign object entering the unit.

Accumulation of dust and debris on all electronics will cause damage which will not be covered by warranty.

4.2.11 Recharging Batteries During Storage

If the unit will be stored for three months or longer, visually inspect, and charge the batteries for 24 hours at regular, three-month intervals, refer to the battery label for battery voltage and use appropriate charger.

Chapter 5. Operation

This chapter describes how to operate the unit.

5.1 Starting the Unit

Please be sure not to start up the unit without the assistance of a factory trained, authorized person as failure to do so may damage the unit and void the unit warranty.

To request a start-up: Either complete the form on line (6002-1545) and email it to service@800pwrsrv.com or fax a printed copy to Power Services at (323) 721-3929.



Caution: Ensure the unit is clean and free of dust and debris.

5.1.1 Preparation of Batteries

9. Ensure proper number of batteries are delivered with your order. Verify quantity against battery drawing inside the door
10. Place battery ID (Number) labels on each battery, refer to Battery Installation and Connection Instruction
11. Ensure batteries are charged within a 3 months period, after the initial receipt, follow the Service Log sheet (6002-2017-04) for battery maintenance scheduling to protect the warranty.
12. Ensure that battery cables are properly torqued to the battery terminals. See torque values table 4.3.
13. Verify that the batteries are in a temperature-controlled environment.

5.1.2 Preparation of Electronics



Caution: Ensure there is proper ventilation and temperature control to ensure **NO MOISTURE** is introduced to the electronics which will void the warranty.

1. Ensure facility load is within full load rating of the electronics. Full load power rating of the unit can be found on name plate within the inner cabinet door.
2. Make sure all input power, output power and DC terminal blocks are properly torqued.



Caution: All loads must be verified for short circuit test before connecting to the output of the unit.



Note: The pre start-up procedure described in this manual is a reference only to a start-up of the UPS for maintenance and shutdown.

5.2 Turning ON the Unit

Follow the instructions below for the UPS operation.

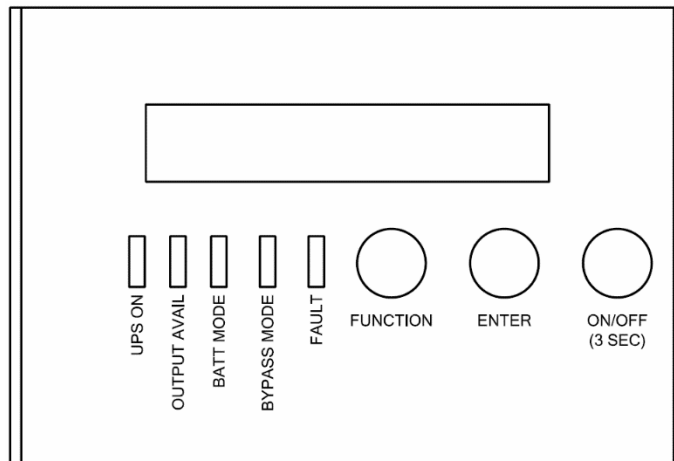



Figure 0-1 LCD Display



- Ensure that installation was correct and successful and that the input power cable is connected to a well-grounded outlet.
- The UPS can be started by pushing the  button on the front panel.
- The UPS should now start its inspection of: internal functions, main synchronization and inverter startup. Then power should start to be supplied via the outlets.
- During this inspection, the LCD will display “Ready on”. The LED shall light up when output power has commenced and the LCD will display “Line mode”.
- Switch on the loads.

Shutting down the UPS









- Shut down and turn off the loads.
- Push the  button on the front panel for five seconds. The alarm will sound and the UPS will shut down.
- The LCD will display UPS OFF for a few seconds.
- In emergency situations, the EPO located on the back of the unit should be used.

5.2.1 Button Operation

Please note the three operating buttons on the front panel:

1. “” is an ON/ OFF button:
 - (a). Push the “” button (at least 3 seconds) to turn on the UPS.
 - (b). When UPS is working, push the “” button (at least 3 seconds) to turn off the UPS.

Operation

2. “” is an Enter button. Use this button to check content of UPS and the method is listed below:
 - (a). Push the “” button (at least 2 seconds) to check content of UPS. Each content can be displayed by pressing at once, and it has fifteen kinds of function to be checked.
 - (b) If no pressing within 10 seconds, it will return to original status.
3. “” is a Function button. Each function can be enabled by pressing this button.
 - (a). Push the “” button (at least 2 seconds) to choose which function that you want.
Each content can be displayed by pressing at once, and it has fourteen kinds of function to be checked.
 - (b). After choosing the function, push the “” button to enter the function that you want.
 - (c). Push the “” button to choose other function again.
 - (d). Push the “” button to enable your function.
 - (e). Push the “” button to confirm and enable your function.
 - (f). If no pressing within 10 seconds, it will return to original status.

5.2.2 Control Panel functions

Operation of the UPS is indicated on the monitor panel with five LED indicators and an LCD screen. This display is also capable of alerting the user with audible alarms.

ON	This green LED is lit when UPS has been turned on.
OUTPUT AVAIL	When the UPS is in normal or static bypass modes, there is voltage at the output terminals and this LED will light up in green.
BATT MODE	While operating in battery mode.
BYPASS MODE	While operating in bypass mode, this LED will light up in yellow.
FAULT	If any internal error occurs in the UPS, this LED will light up in red and give off an audible alarm. Press any of the buttons on the front panel to turn off the alarm.

Status of the UPS, measurements and alarms are all indicated on the LCD screen.

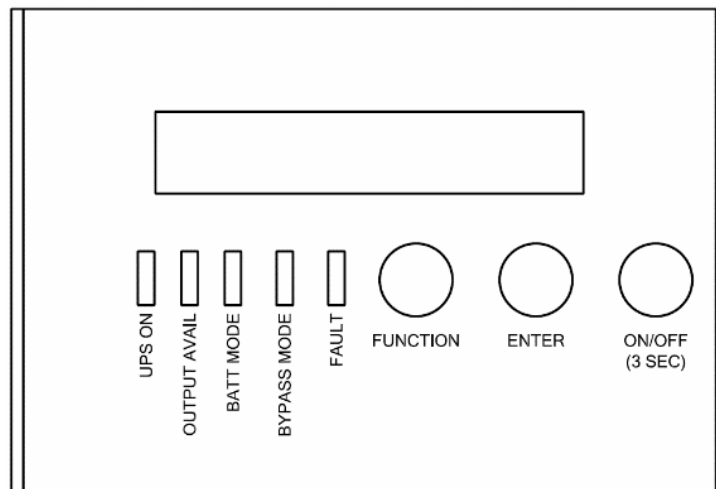

5.2.3 Normal Display



The UPS status is shown in normal display mode. From here you have a choice to go to UPS meters display and the Setting display by pushing the button.

5.2.4 UPS meters Display





Various measurements are available through the UPS meters display; pressing the button will scroll through the following meters:

LCD message	Description
O/P VOLT= xxx, xV	Shows Output AC voltage
O/P FREQ= xx, x Hz	Shows Output Frequency
I/P VOL T= xxx, xV	Shows Input AC voltage
I/P FREQ= xx, x Hz	Shows Input Frequency
BAT VOLT= xx,xV	Shows Battery Voltage
O/P LOAD%= xx%	Shows Load % of max load
O/P W= xW	Shows Output Watts
O/P VA= xVA	Shows Output VA
O/P CURR= xA	Shows Output Current
BACKUP TIME= xx min	Shows Estimated Backup time in minutes
BAT CHARG= xx%	Shows approximate percentage of Battery capacity
TEMPERATURE= xxC	Shows approximate ambient temperature
BAT PACK NUM= x	Shows External Battery Pack Number
RATING = xxxxVA	Shows UPS Rating
CPU VERSION xx.x	Shows CPU Version

5.2.5 UPS configurations

1. Various settings that have been chosen are shown in the UPS setting display.
2. To enter configuration mode, press the  button for one second. The first configuration parameter will be shown on the LCD display.
3. Press the  button to scroll through the parameters.

Operation

4. Press the  button to select the parameter.
5. Press the  button to scroll through the options for the selected parameter; Press the  button to select the option.
You may be prompted to save the selection, if so press the  button to either confirm or save your selection. Other options are saved and started automatically. See the table below for further details.
6. If no buttons are pressed (or user inactivity) for ten seconds, the UPS shall exit the configuration mode and return to normal mode displaying Line mode.

Caution!

The factory default settings do not necessarily have to be changed, although you are free to tailor the UPS to your specific needs.

Settings	LCD display	Explanation	Selection	Factory
Output Volt. Setting	O/P V Setting	Select Nominal Voltage	208/220/230/240 V	230V
			100/110/115/120/127 V	120V
Input Frequency	I/P F Setting	Select input frequency range when UPS goes into free run mode	±2% ±5% ±7%	±5%
Input / Bypass Voltage	I/P Bypass Set	Select Input Voltage range when bypass is available	±10% +10/-15% +15/-20%	+10% -15%
Free Run Mode	Free Run Set	Select if UPS can run in Free run mode (unsynchronized)	ON/OFF	ON
Bypass Enable/Disable at Free run mode	Bypass disable	If Enable is chosen, the UPS can go to bypass when unsynchronized.	Disable/Enable	Disable
HE mode Setting	HE Mode Set	Select if UPS runs in high efficiency mode	ON/OFF	OFF
Force Manual Bypass	Manual bypass	Permanently force UPS to bypass. For service only.**	ON/OFF	OFF
Management of Load groups	Outlet Setting	You can put the two load groups on and off form front panel	1 ON & 2 ON 1 OFF & 2 ON 1 OFF & 2 OFF	Both load segment
Do Battery Test	Battery Test	Detect battery is normal or not.		

Operation

Silence Function	Silence Set	Enable or disable silence function	ON/OFF	OFF
Number of External battery Packs	Bat Cabinet Set	This setting is needed For UPS to predict Backup time	0 (only internal batteries) 1 (one external cabinet) 2 (two external	0
Site wiring alarm	Sit Fault Set	You can enable or disable the site wiring alarm	Enable /Disable	Disable
Select Language	Language	Select load language	English, German, French, Spanish, Italian.	English
Set Generator Mode	Generator	Set unit in generator mode. ***	ON/OFF	OFF
Set RS232 communication	RS232 Control	Set RS232 communication enable or disable	Enable/Disable	Enable

5.2.6 Manual test of the UPS

Manual UPS or Manual Battery tests can be conducted from the UPS configuration as well and are functional even when the UPS is not charging the battery.

Manual Battery test: Scroll the parameters until Manual Bat test displays on the LCD.

Press the  button twice.

*****) Note: In order for the UPS and power management software to operate normally, Manual Bypass should always be set to OFF as the load will not be protected by the unit when Manual Bypass is ON. This is aimed for operating an external maintenance bypass switch.**

******) Note: You should turn UPS off and keep the AC power before you use “Generator” function. (even you want to select “\Generator\OFF” to back to normal mode).**

5.2.7 Interpreting UPS messages

Troubleshooting procedures described here give simple instructions in determining UPS malfunctions.

Start the troubleshooting procedure if you witness any alarm indication on the control panel.

5.2.8 Alarm indicators

The UPS gives the following audible alarms:

- If UPS is on battery and the ON BATTERY LED is on, UPS will beep every 5 seconds.
- If the battery capacity is low and the ON BATTERY LED is flashing, the UPS will beep twice every 5 seconds.
- If UPS is on bypass and the BYPASSED LED is on, UPS will no beep.
- If UPS has an internal fault and the ALARM LED is on, the UPS will give a constant audible alarm displaying the cause on the LCD display.

5.2.9 Silencing an alarm

By pressing any of the three buttons on the front panel, the alarm can be turned off, except when the battery is low, which will cause the alarm to resound.

On the LCD display, you can also choose silent alarm mode which will not warn you of any malfunction audibly.

5.2.10 Connecting the UPS to a Computer (Optional RS232, USB) port

The communication device for the UPS and PC comes as a complete package with power management software. Only the communication cable provided with UPS may be used to connect to your computer, which is accomplished through the UPS RS232 port. Also ensure that the operating system on your computer is supported. Instructions provided in the power management software will help with this installation.

•RS-232 Standard Interface port



Pin #	Signal name	Caution! Max rated values 12Vdc	Functions
2	TxD	Output	TxD Output
3	RxD	Input	RxD / Inverter Off Input
5	Common		Common
6		Output	Ac Fail Output
8		Output	Low Battery Output
9		Output	12 VDC Power

• USB port (option)

Connecting the UPS to your computer is accomplished through the USB port on the back of your computer. USB compliant hardware and operating system will be necessary including installation of a UPS driver. The serial port cannot be used when using the USB port. The USB cable is standard and can be bought separately.

Chapter 6. Troubleshooting

This chapter describes typical troubleshooting steps.

Troubleshooting

Displayed on LCD	Audible Alarm	Alarm Description	What You Should Do
Output Overload	Two Beeps per second	The UPS is overloaded (in Line Mode). Your equipment needs more power than the UPS can provide. The UPS operates in bypass.	Shut off the least important equipment connected to the UPS. If this solves the overload problem, the UPS will switch from bypass back to normal operation.
Battery Test	No Beeps	The UPS is doing a battery test.	No action needed. The UPS will return to normal operation when it successfully completes the battery test.
Over-Charge	Constant beep	Batteries are overcharged.	Turn off protected loads. Turn off UPS and call your local dealer
Low Battery	2 beeps every 5seconds	The unit is operating on Battery Power and will shut down soon due to very low battery voltage	The unit will restart Automatically when acceptable power returns.
On-Battery	Once every 5 seconds	The unit is operating on Battery Power.	Save your data and perform a controlled shutdown.
Charger Failure	Constant beep	Charger has failed.	Phone the local dealer
Over-Temperature	Constant beep	High ambient Temperature.	Make sure the unit's fans and vent holes are not blocked, and make sure the ambient surrounding temperature is not above 40 degree C. If these conditions did not solve the problem, call your service representative.
Output Short	Constant beep	Output short circuit	Call the Local dealer
High output Voltage	Constant beep	High output voltage	Call the Local dealer
Low Output Voltage	Constant beep	Low output voltage	Call the Local dealer

Troubleshooting

Displayed on LCD	Audible Alarm	Alarm Description	What You Should Do
Bus Fault	2 Beeps per second	High internal DC bus Voltage.	Turn off protected loads. Turn off UPS and call your local dealer
Site wiring Fault	1 Beep per second	Voltage detected Between Neutral and Ground	UPS mains connector polarity Wrong. Rotate the connector UPS installed to mains supply without ground.
Line abnormal	1 Beep per second	Wrong AC Line backed up during auto restart	

Appendix A – Options

This appendix provides detailed information about the options available for the Single-Phase Lighting Inverter

A.1 Auxiliary Transient Voltage Surge-Suppressor (TVSS)

The TVSS contains energy-absorbing components designed for specific line configurations. If protection components become damaged by absorbed transients, the device shows a reserve flag that indicates a need for replacement. The unit remains operational, but without surge protection.

A.2 Auxiliary Output Circuit Breaker 10 amp (max. 3)

These 1-pole, 10A circuit breakers are designed to protect customer circuits and are offered at a maximum of three auxiliary circuit breakers per unit.

Offered in the following options:

- **Normally ON C.B. option**
- **Normally OFF C.B. option**

A.3 Simple Network Management Protocol

This option consists of an SNMP Powercon mini-internal device and is accessible via RJ45 connection(s).

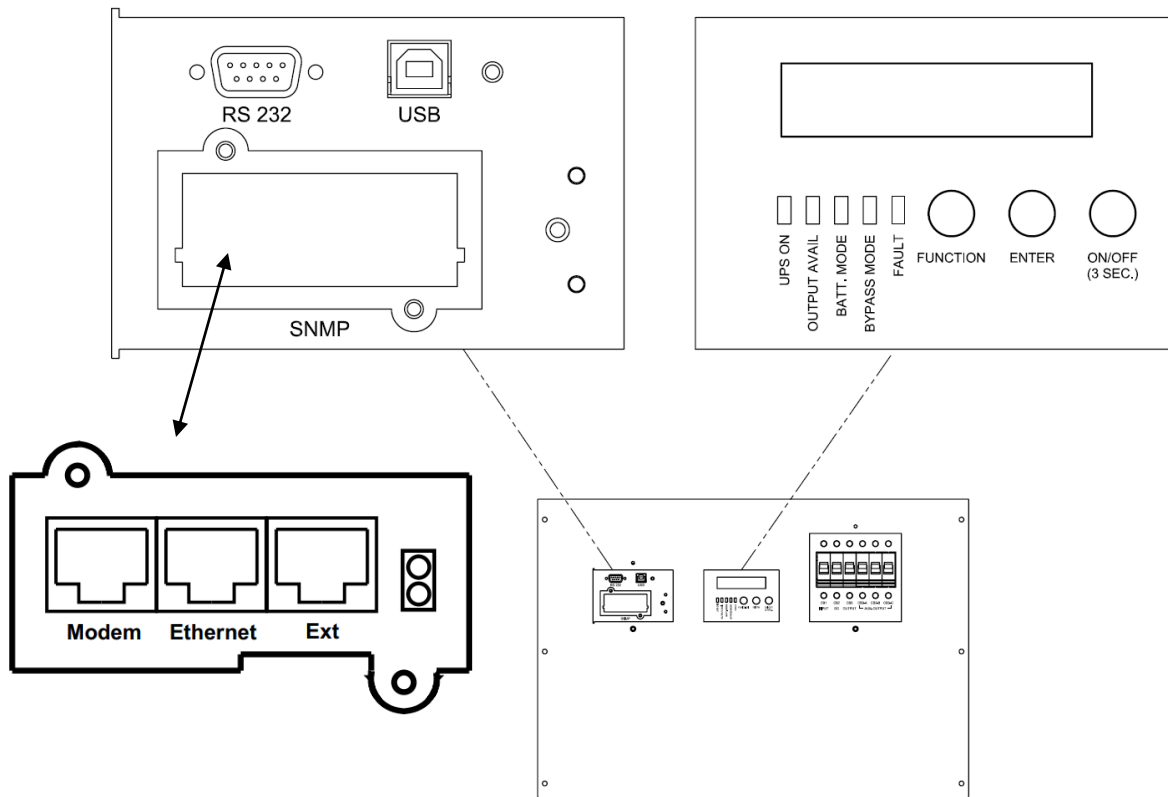

A.4 Communication interface, RS232

The communication device for the UPS and PC comes as a complete package with power management software. Only the communication cable provided with UPS may be used to connect to your computer, which is accomplished through the UPS RS232 port. Also ensure that the operating system on your computer is supported. For further information, refer to **Section 5.2.10** of this document.

A.5 Floor mount brackets

This wall mountable unit can be re-configured into a floor-mountable unit via two brackets beneath the machine.

Note: Customer must consider differences between wall mount & floor mount dimensions before installation!

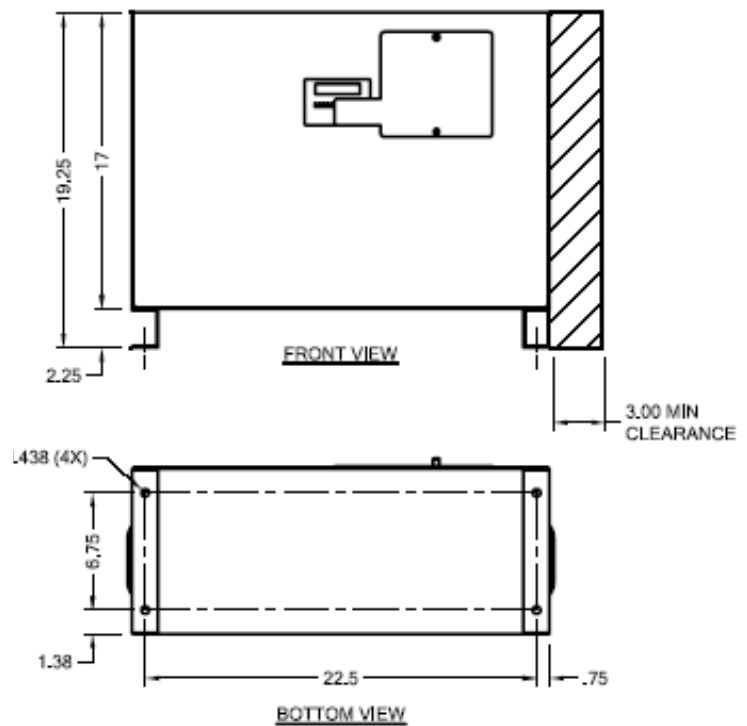
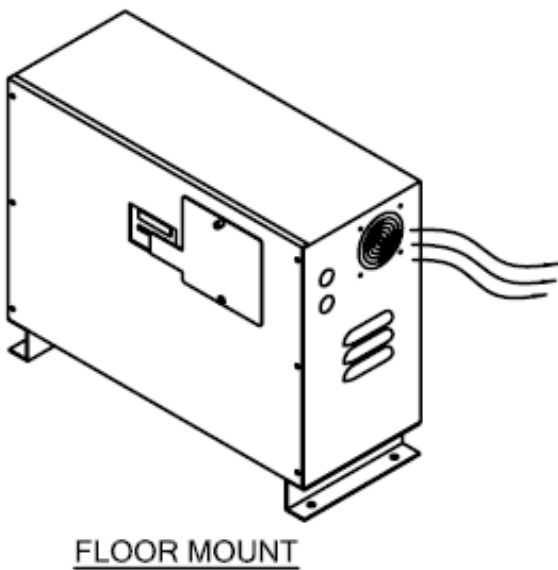

A.6 Remote Status

Five dry relay contacts are used in conjunction with the LCD Display Panel for remote monitoring.

A.7 Facility Interface (Dry Contacts)

Five dry relay contacts are used in conjunction with the LCD Display Panel for facility monitoring and control.

Appendix B – Specifications

This appendix provides detailed information on the electrical and physical characteristics of the Single-Phase Lighting Inverter.

Specifications

Specifications for 120V/277V				
Capacity (W)		200W	300W	490W
Input	Voltage	Single Phase 120Vac or 277V		
	Voltage Range	120Vac ±10% or 277V		
	Frequency	50Hz or 60Hz +/- 4Hz		
	Power Factor	> 95%		
Output	Voltage (on battery)	Single Phase 120Vac or 277V		
	Voltage Range	120Vac ±2% or 277V		
	Frequency (on battery)	50 / 60 Hz +/-0.5%		
	Transfer Time	0 ms		
	Overload Recovery	Auto transfer to UPS		
	High Efficiency mode (AC to AC)	> 95 %		
	UPS Design Technology	On-Line / Fully digitized microprocessor controlled		
Protection and Filtering	Surge Protection	120V (IEEE C62.41) / 230V (IEEEC61000-4-5 level 3)		
	Overload Protection	125% for 1 minutes and 150% for 10 seconds		
	Short Circuit Protection	Circuit breaker		
System/Display/ Warning	Visual Display (LED model)	UPS on(green), line-mode(green), battery mode(yellow), bypass(yellow), fault(red)		
	Visual Display (LCD model)	Input / output voltage, input / output frequency, on-line mode, back up mode, battery capacity, load level		
	Audible Alarm (Battery back-up)	Beep every 5 sec		
	UPS Fault	Continuous beeping sound and LCD display		
	Communication	RS-232 Serial Port and USB		
Battery	90 min.	2X35 A/H	2X50 A/H	2X50 A/H
Dimensions	Inches (width x Height x depth)	24 x 17 x 9.5		